



(19) **United States**

(12) **Patent Application Publication**
Yi et al.

(10) **Pub. No.: US 2003/0052596 A1**

(43) **Pub. Date: Mar. 20, 2003**

(54) **ORGANIC ELECTROLUMINESCENCE
DISPLAY AND FABRICATING METHOD
THEREOF**

Publication Classification

(51) **Int. Cl.⁷ H05B 33/00**

(52) **U.S. Cl. 313/504**

(75) **Inventors: Seung-jun Yi, Seoul (KR); Kyung-hee
Choi, Seoul (KR); Do-hyun Choi,
Seoul (KR); Young-chan Choi,
Kyonggi-Do (KR)**

(57) **ABSTRACT**

Correspondence Address:
**BIRCH STEWART KOLASCH & BIRCH
PO BOX 747
FALLS CHURCH, VA 22040-0747 (US)**

Disclosed is an organic EL display and fabricating method thereof enabling to reduce a process time by simplifying a fabricating process in a manner that a pattern of a single insulating layer is formed so as to have both functions of insulator and separator, increase an opening ratio, and reduce a product cost. The present invention includes a plurality of stripe type first electrodes on a transparent substrate, an insulating layer pattern stacked on the transparent substrate and the first electrodes so as to cross with the first electrodes, a half tone pattern of insulator stacked on the transparent substrate between the insulating layer pattern and between the first electrodes, a plurality of organic light-emitting layers on a plurality of the first electrodes, respectively, and a plurality of second electrodes on a plurality of the second electrodes.

(73) **Assignee: CLD, Inc., Seoul (KR)**

(21) **Appl. No.: 10/243,829**

(22) **Filed: Sep. 16, 2002**

(30) **Foreign Application Priority Data**

Sep. 15, 2001 (KR) 2001-57046
Aug. 2, 2002 (KR) 2002-45940

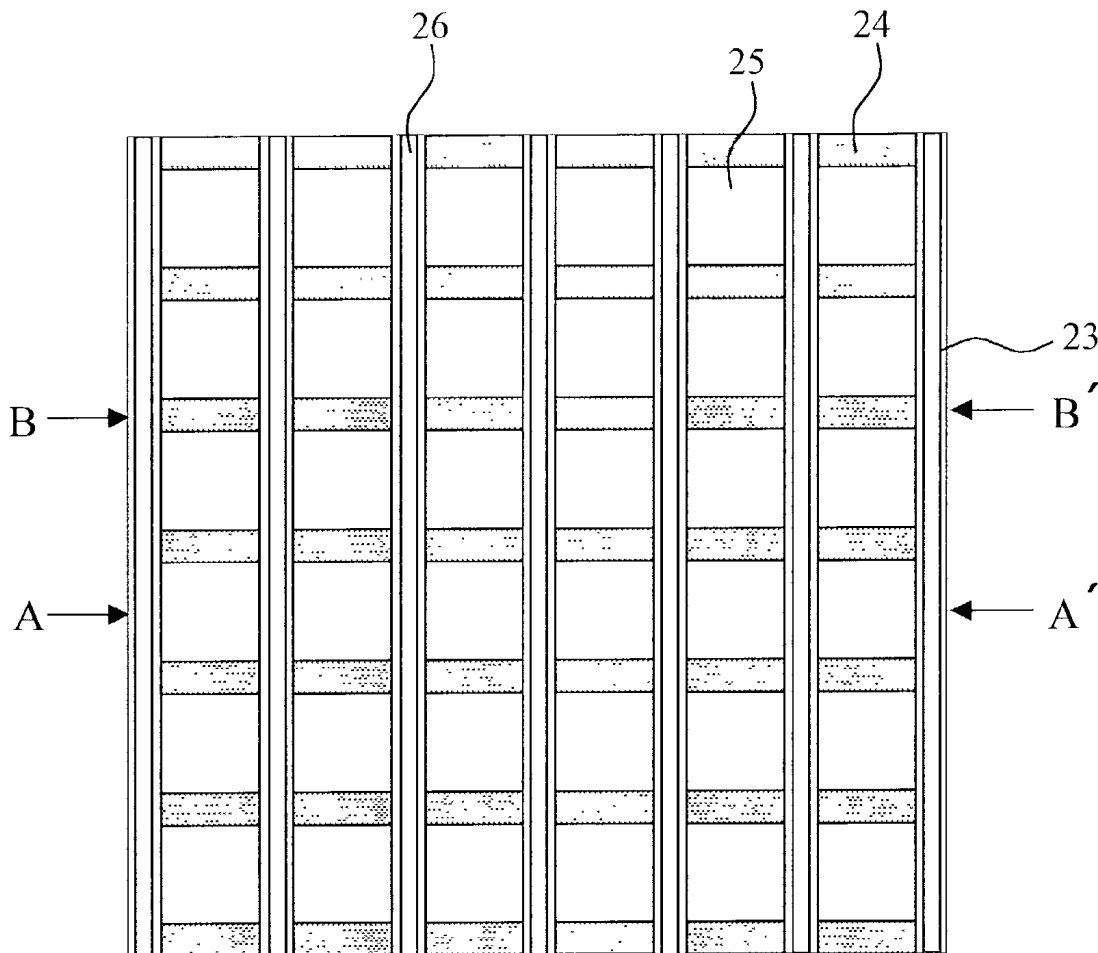

FIG. 1A

RELATED ART

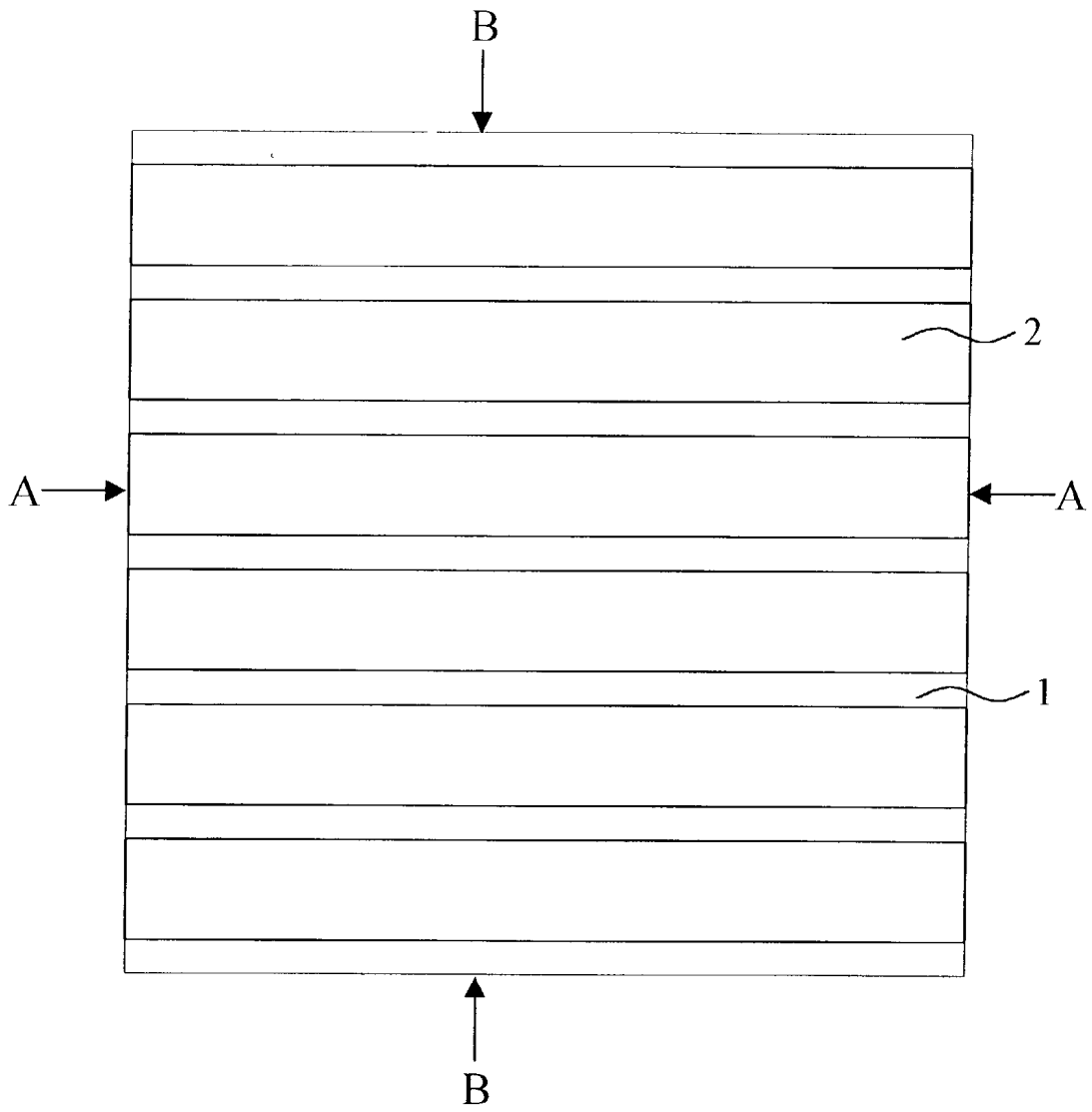

FIG. 1B

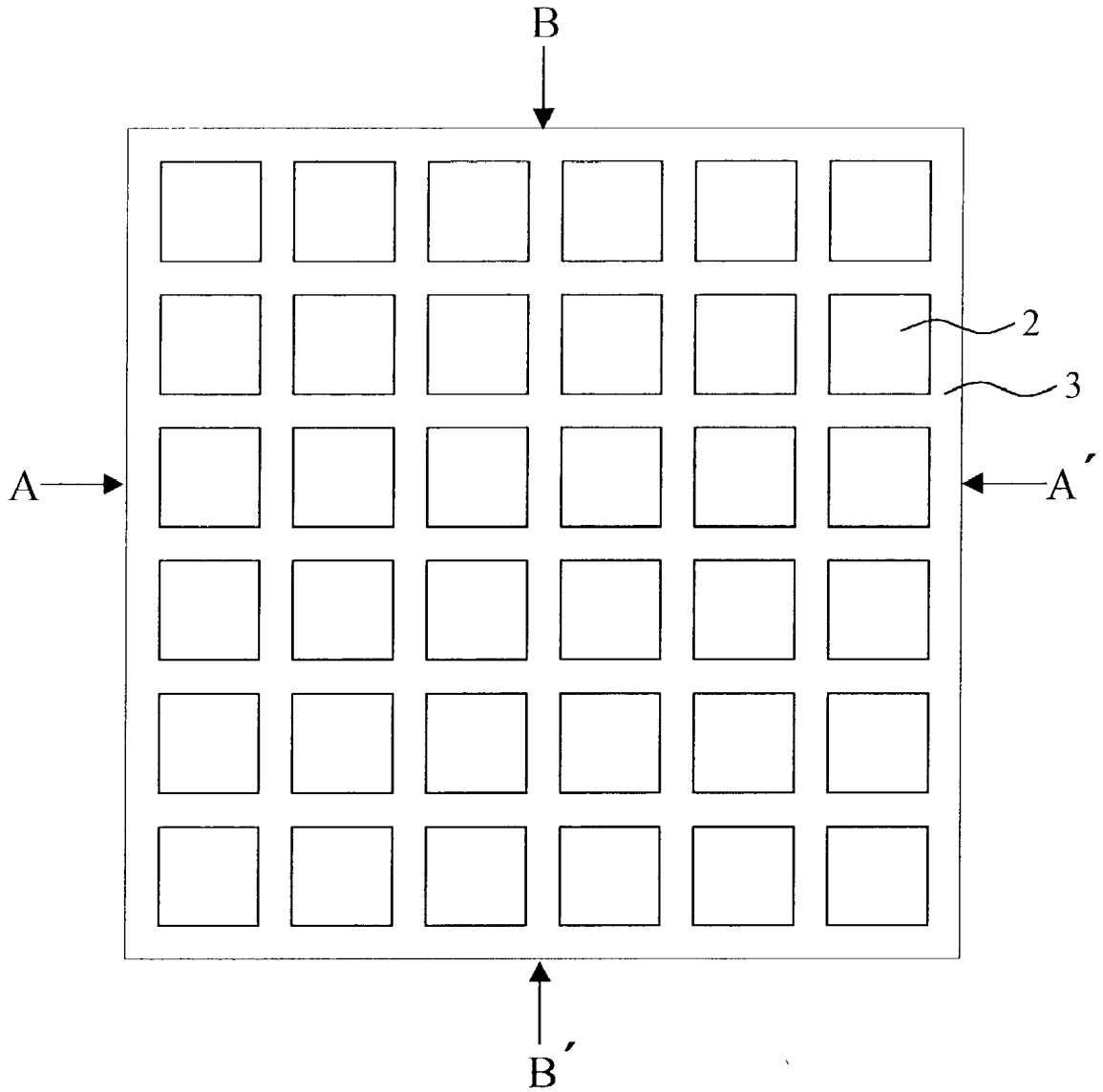

FIG. 1C

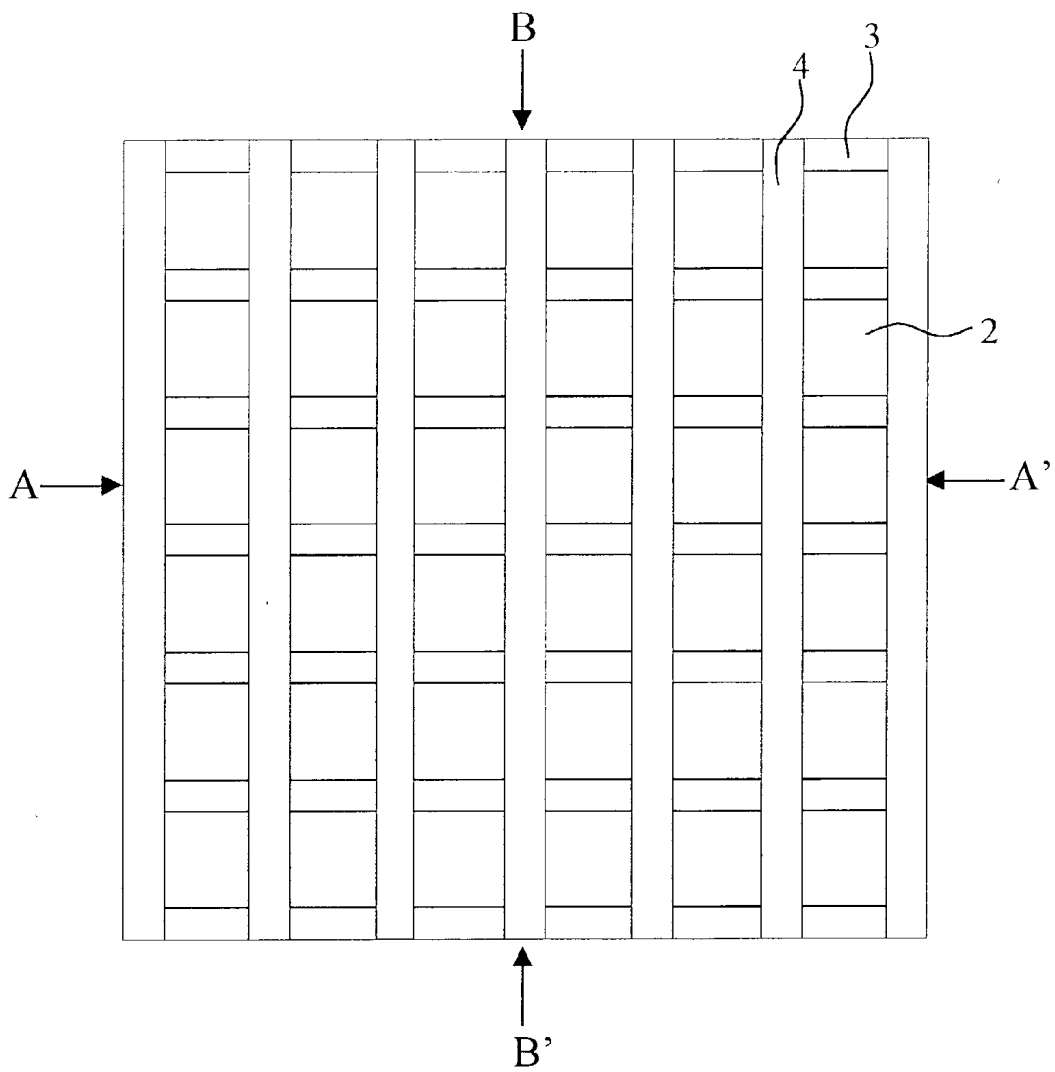

FIG. 2A

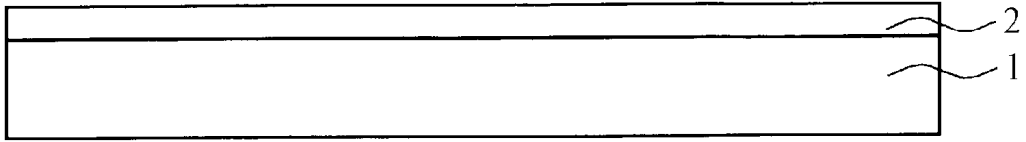

FIG. 2B

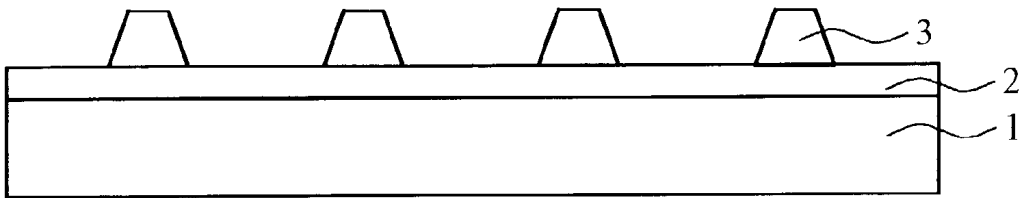

FIG. 2C

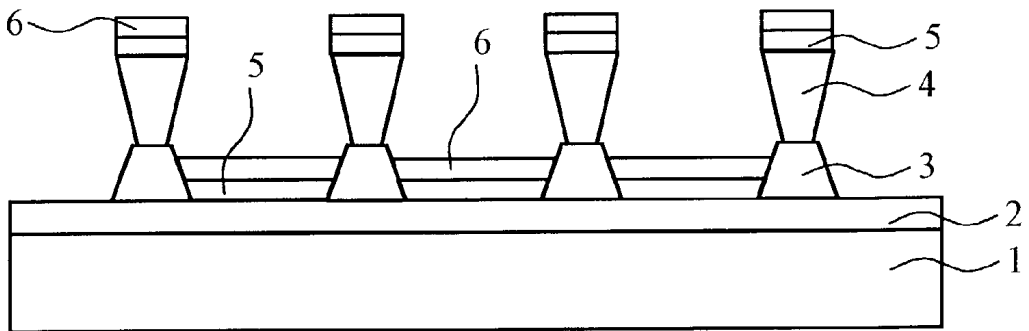

FIG. 3A

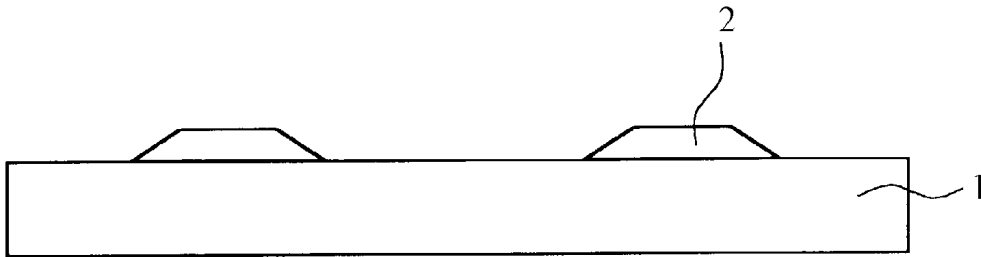

FIG. 3B

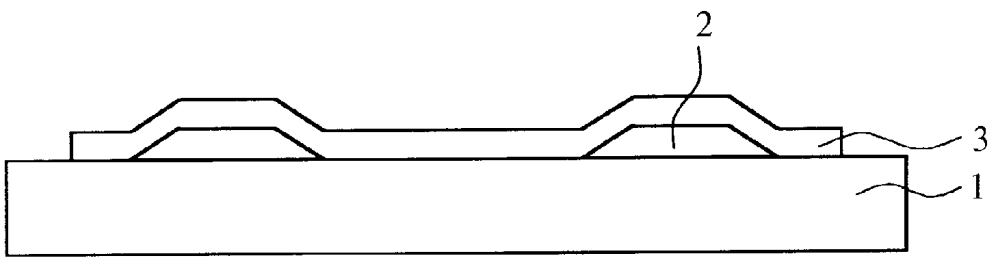

FIG. 3C

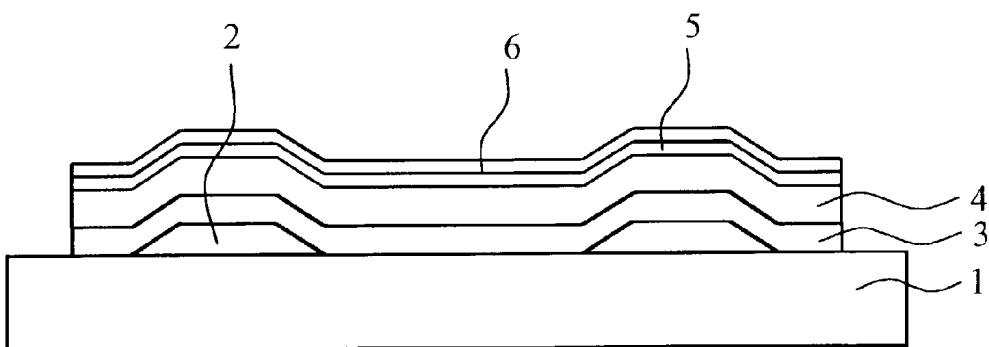

FIG. 4A

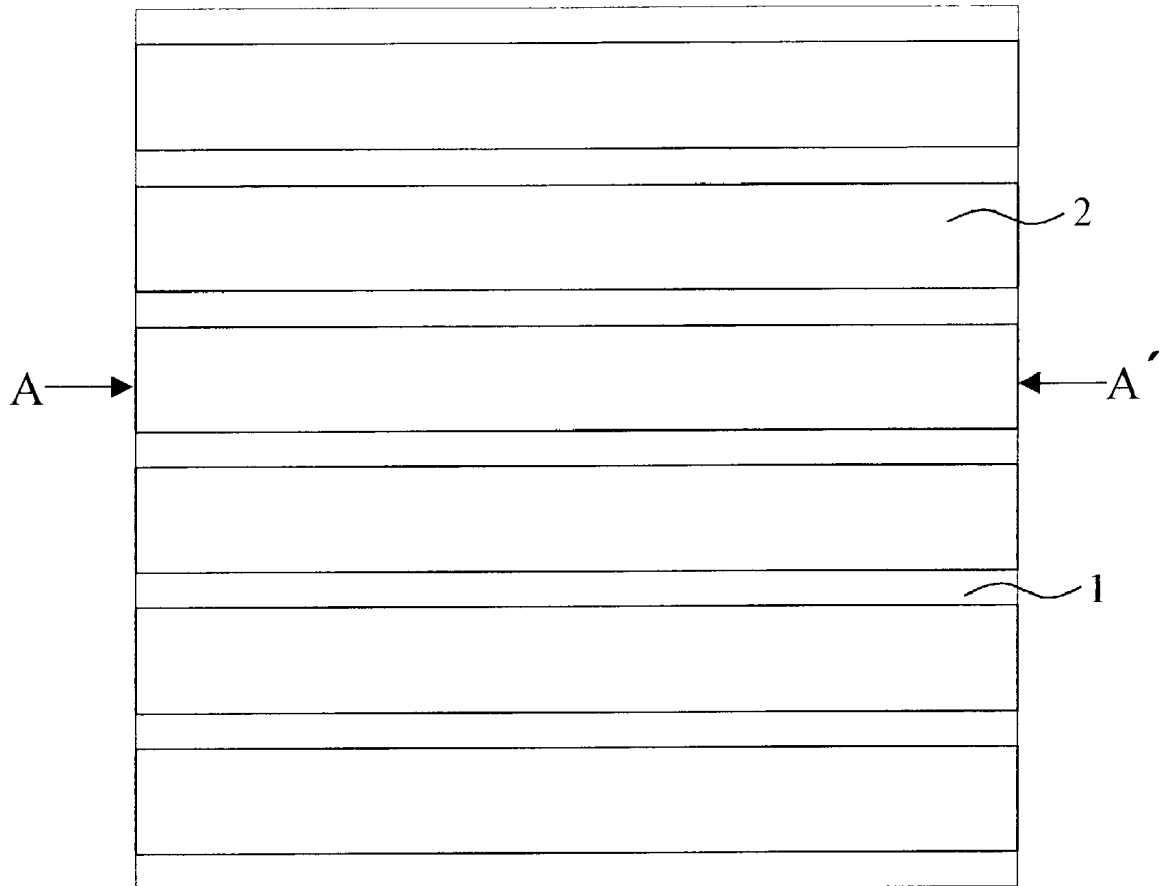

FIG. 4B

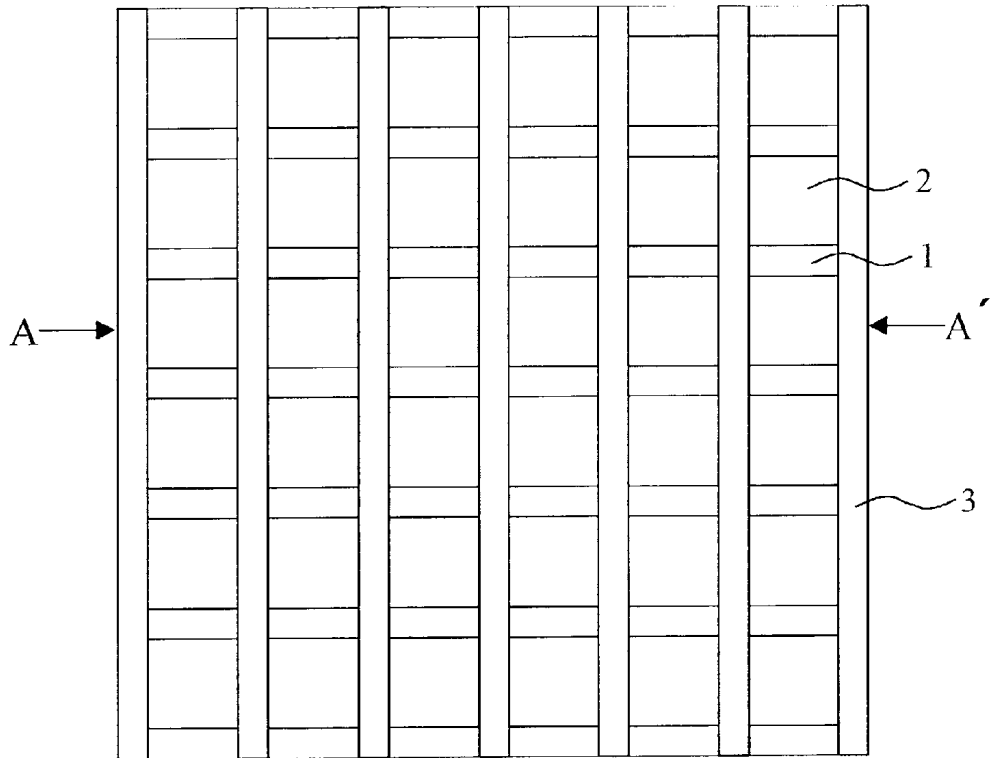

FIG. 4C

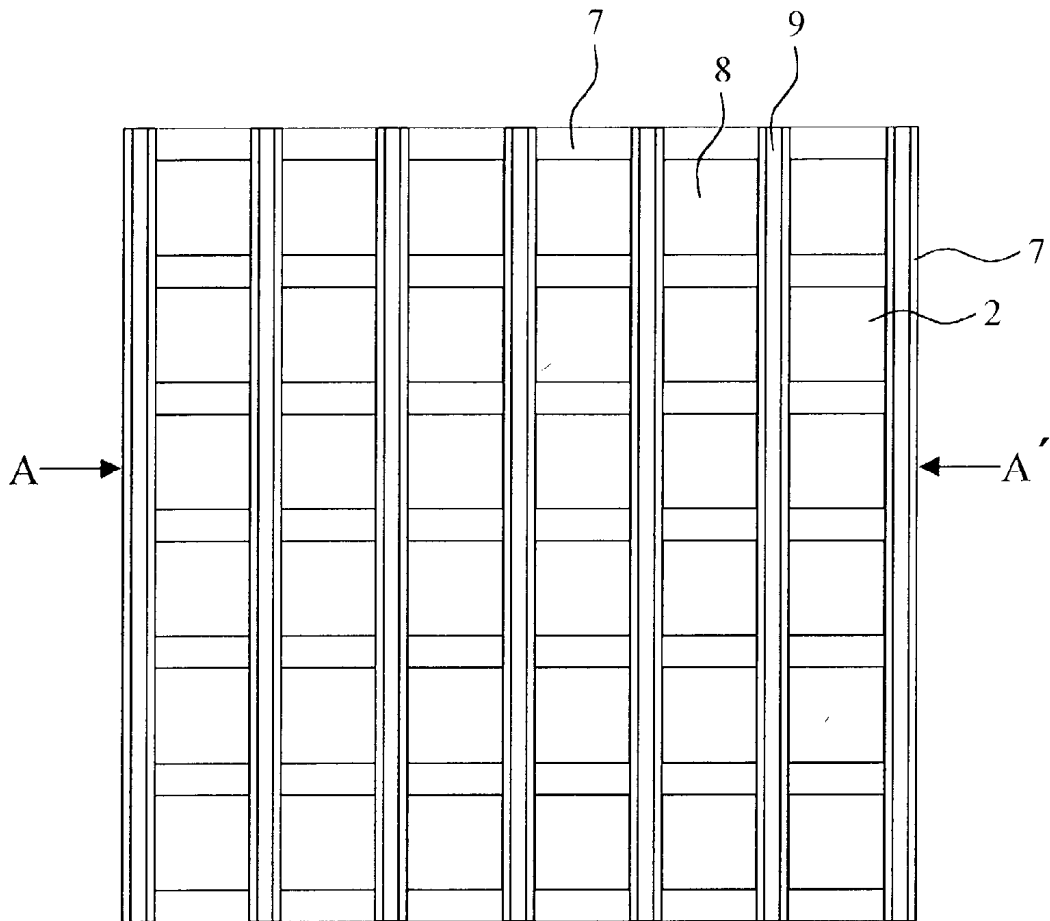

FIG. 5A

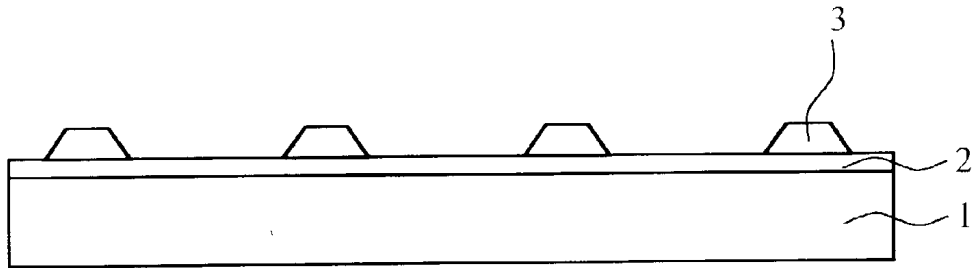

FIG. 5B

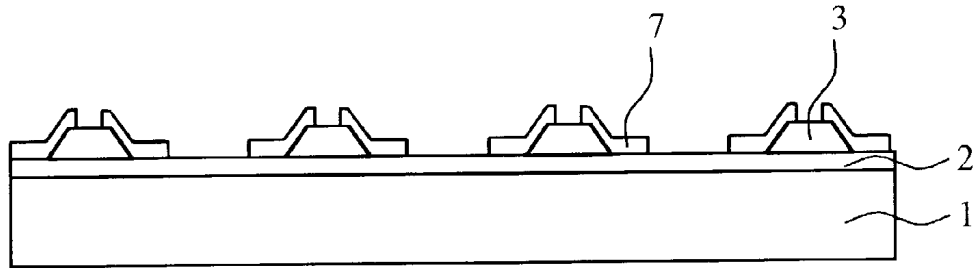

FIG. 5C

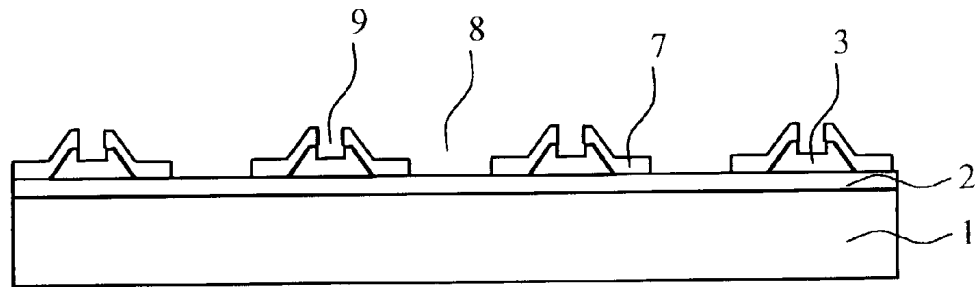

FIG. 6A

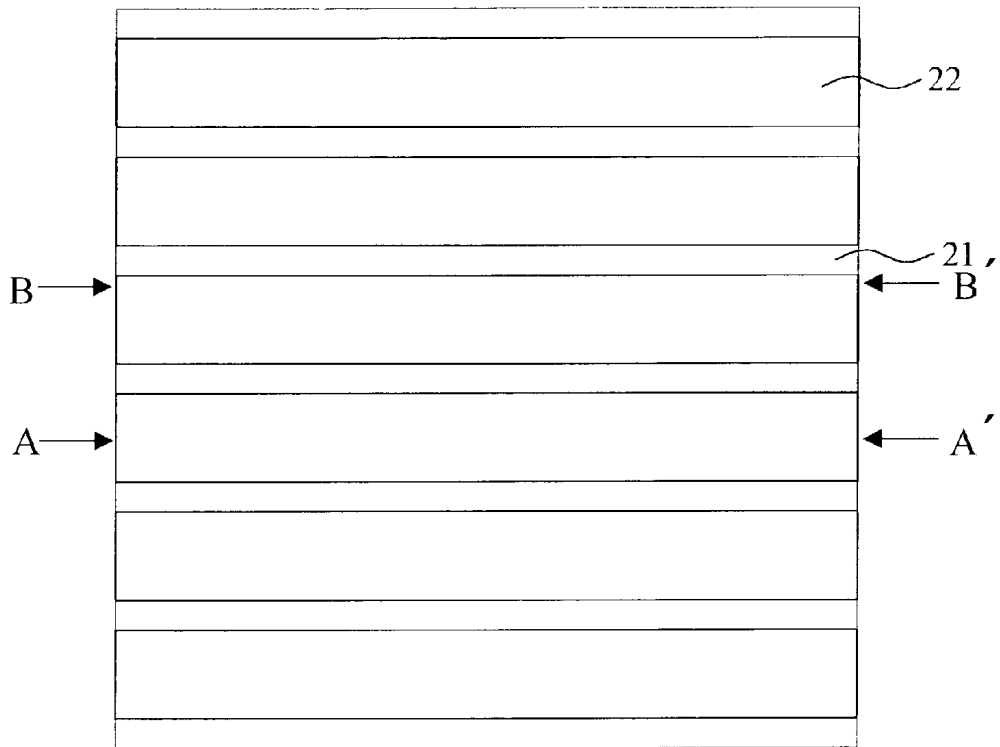

FIG. 6B

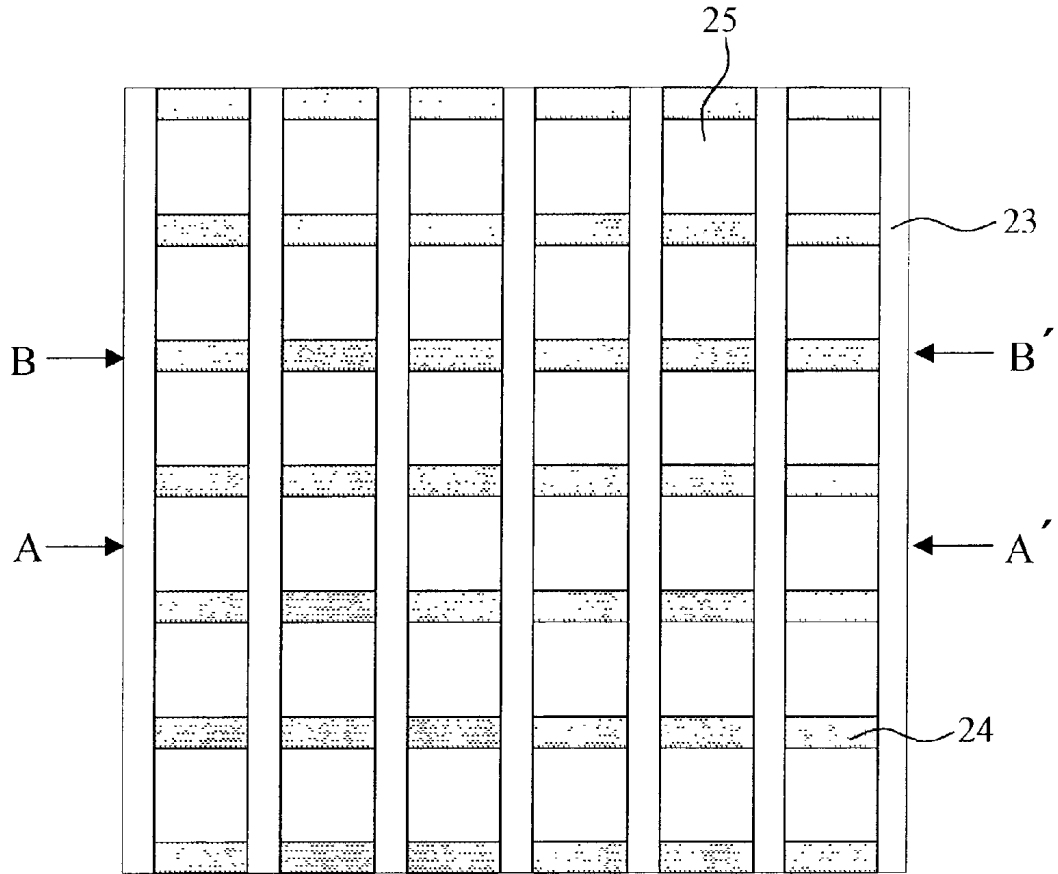

FIG. 6C

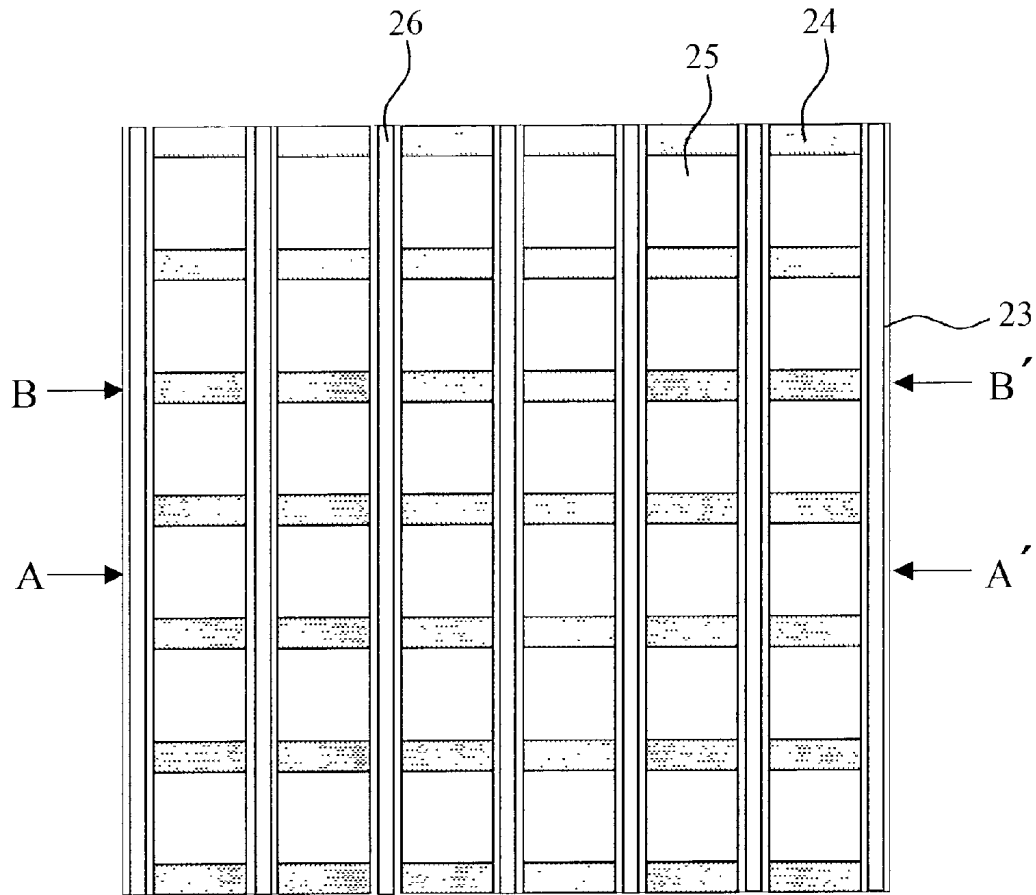

FIG. 7A

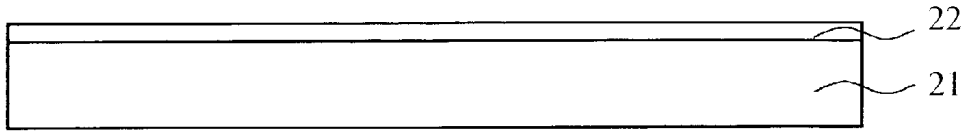

FIG. 7B

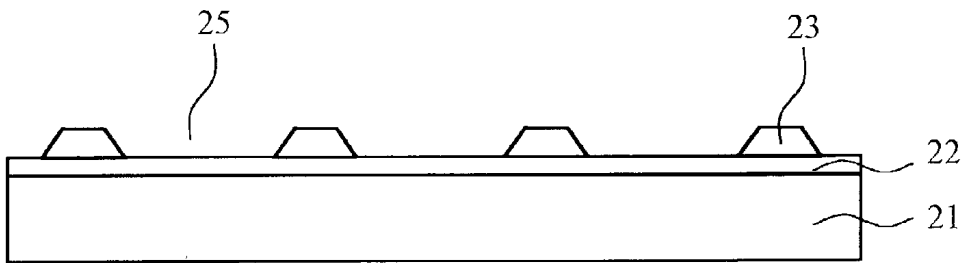

FIG. 7C

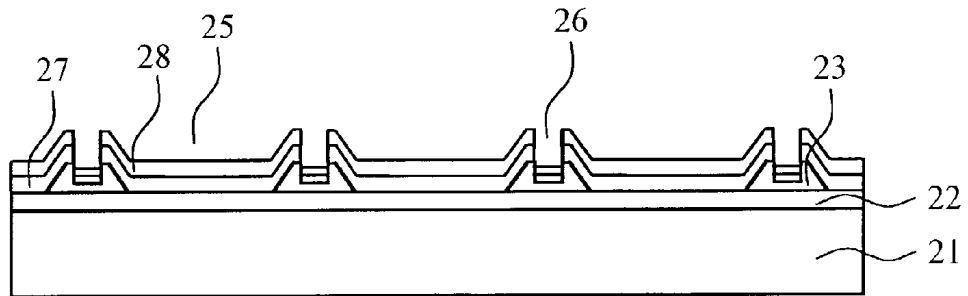

FIG. 8A

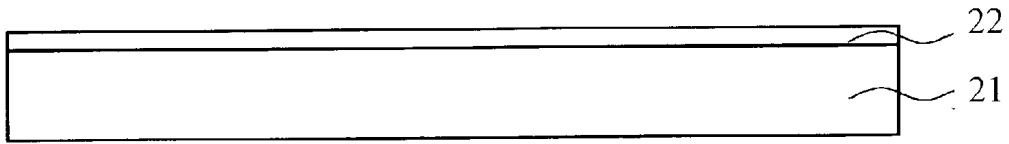

FIG. 8B

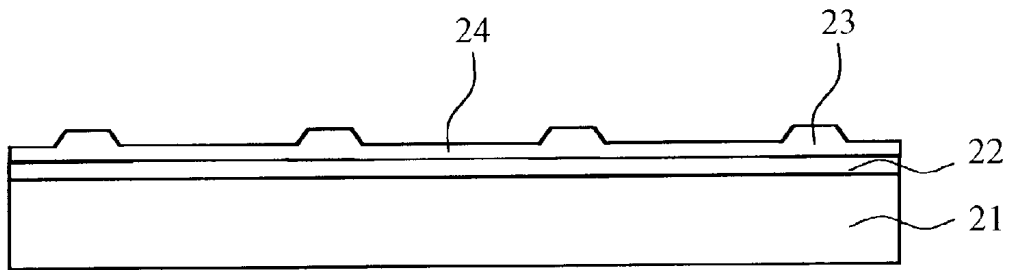

FIG. 8C

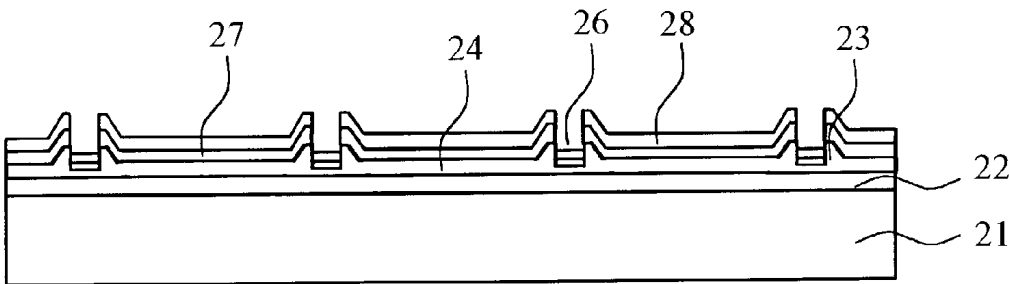

FIG. 9A

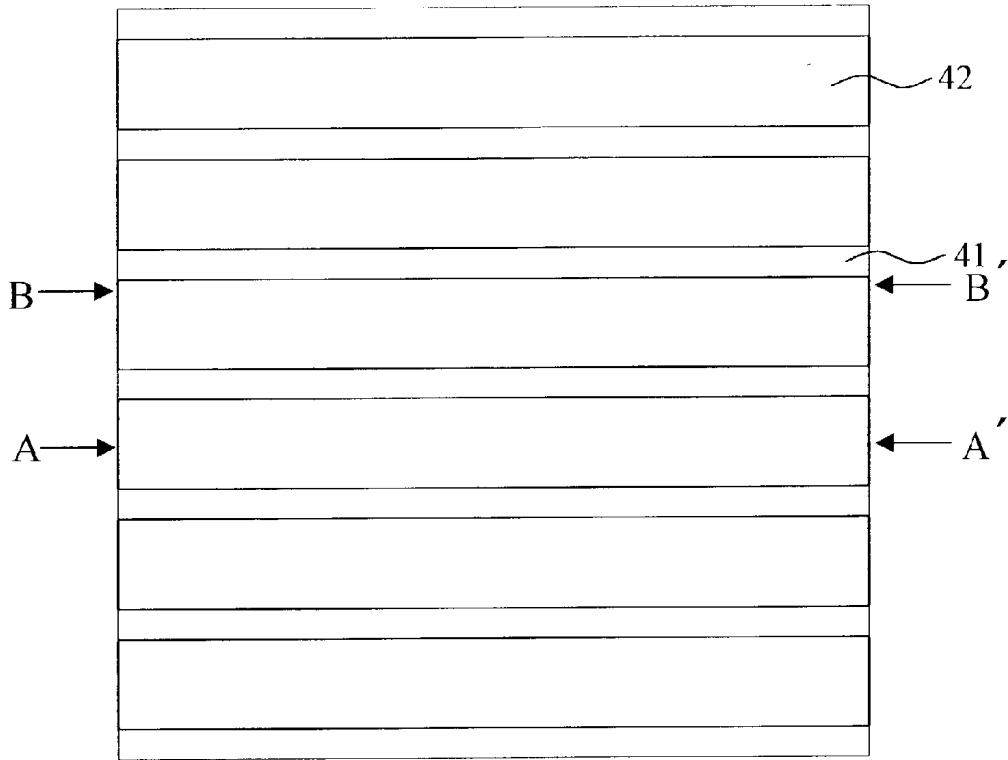

FIG. 9B

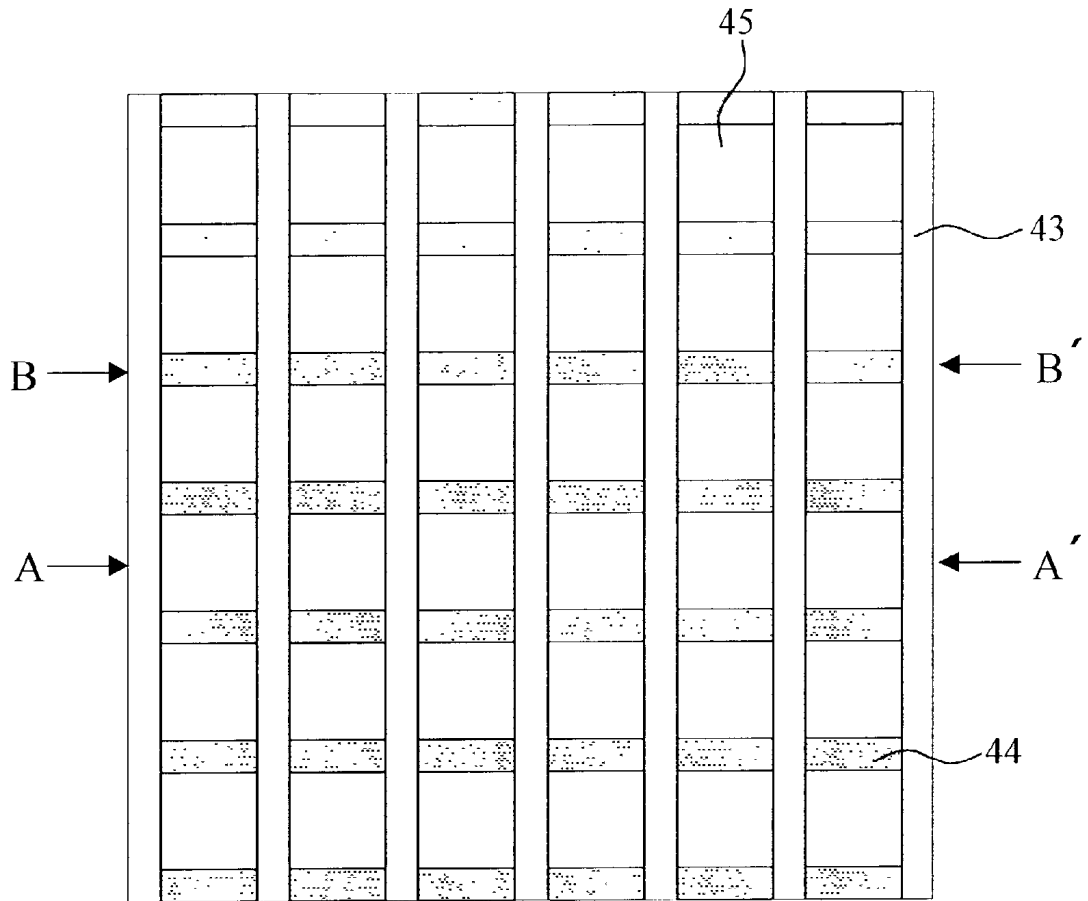

FIG. 10A

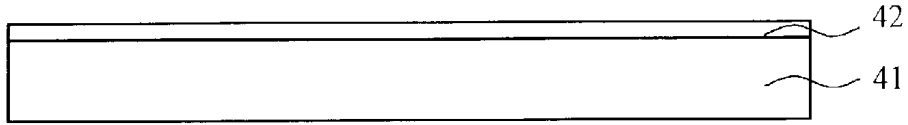

FIG. 10B

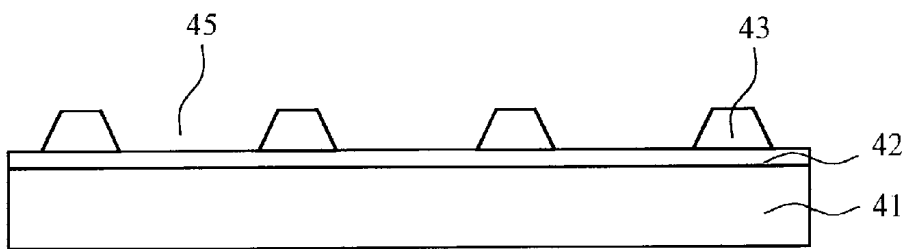

FIG. 10C

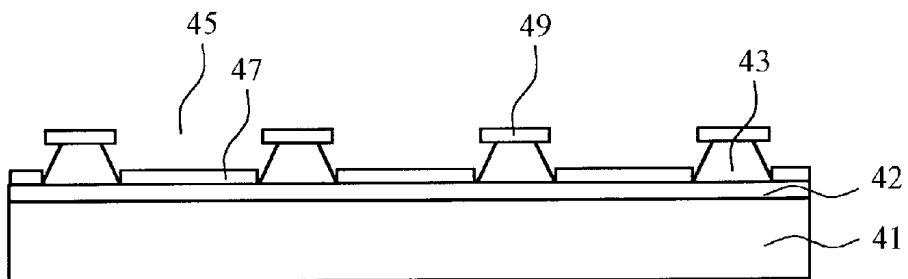

FIG. 10D

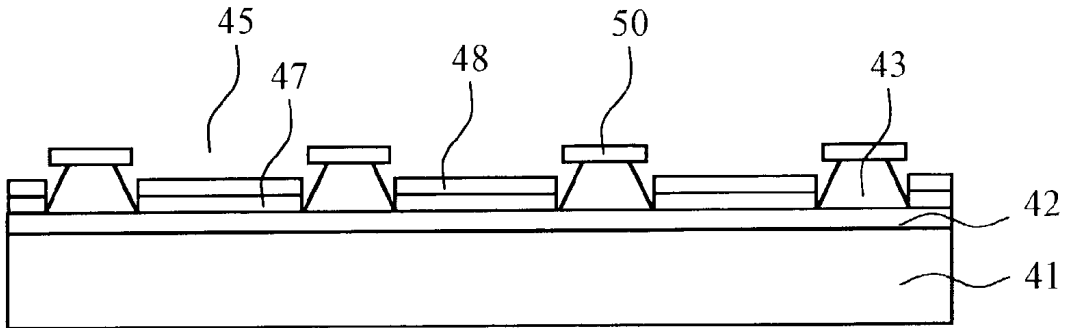

FIG. 11A

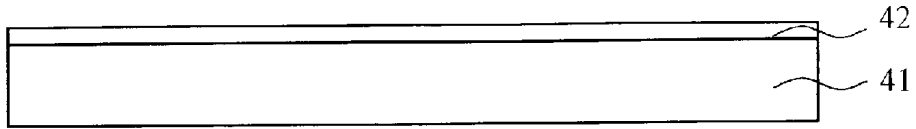

FIG. 11B

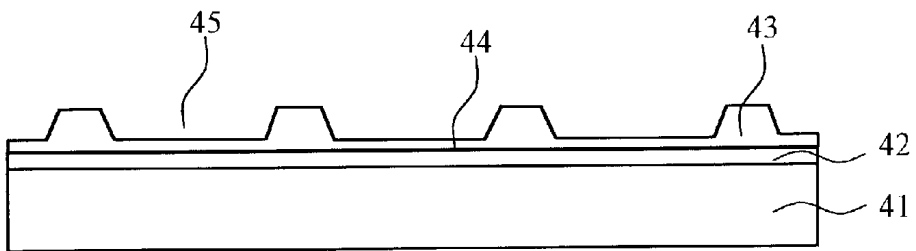

FIG. 11C

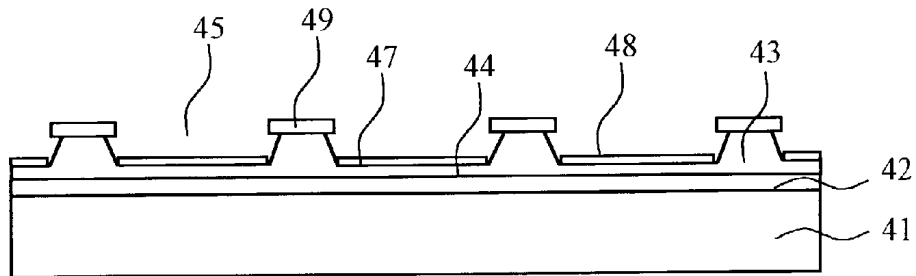

FIG. 11D

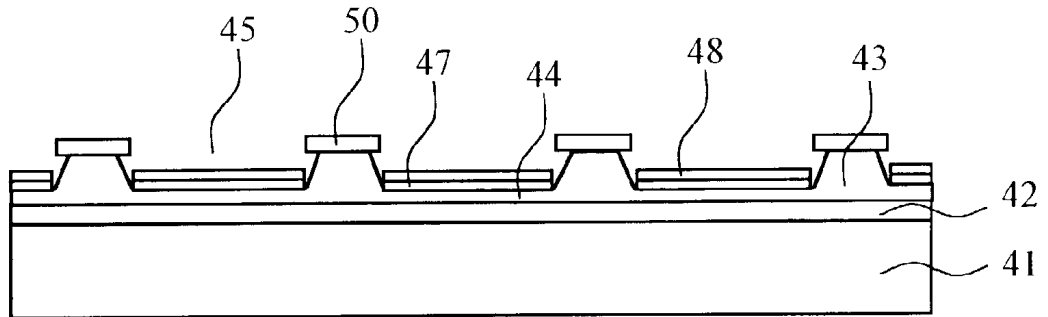

FIG. 12A

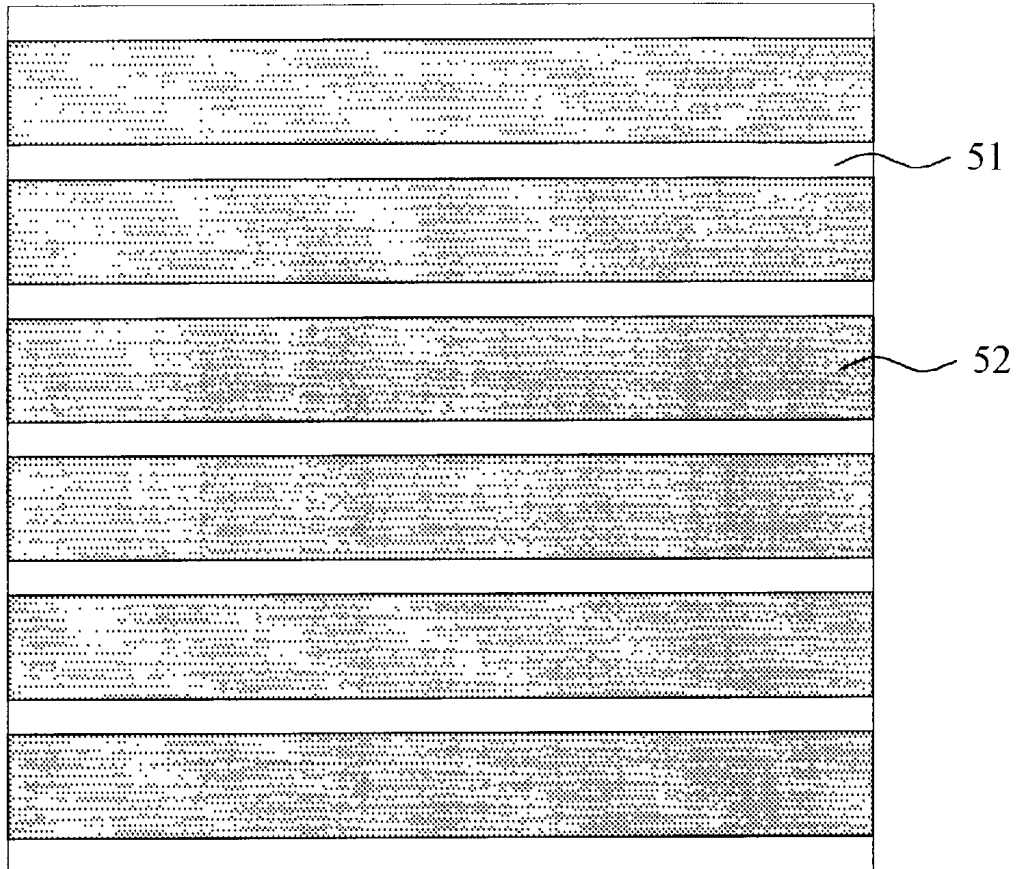

FIG. 12B

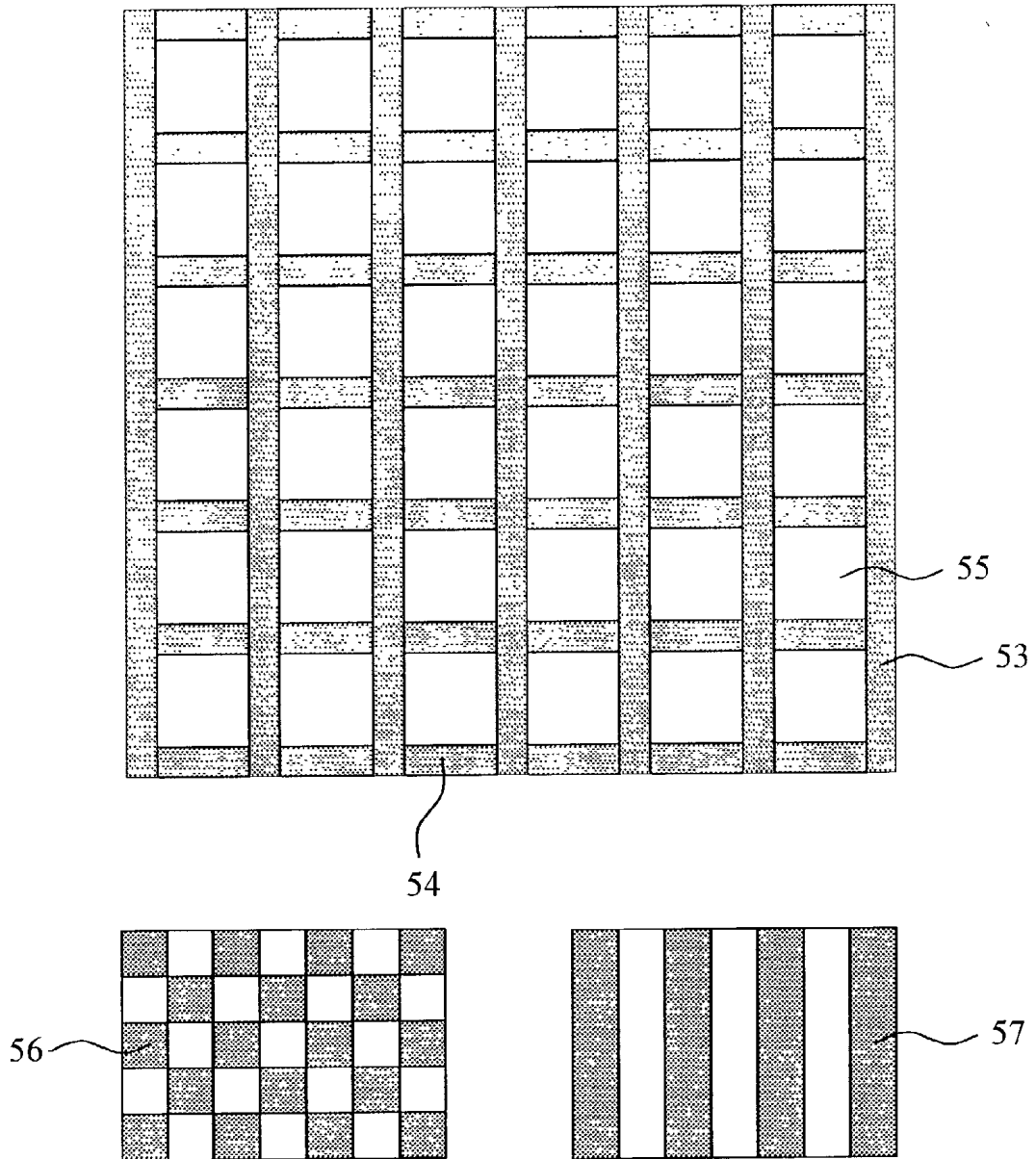

FIG. 12C

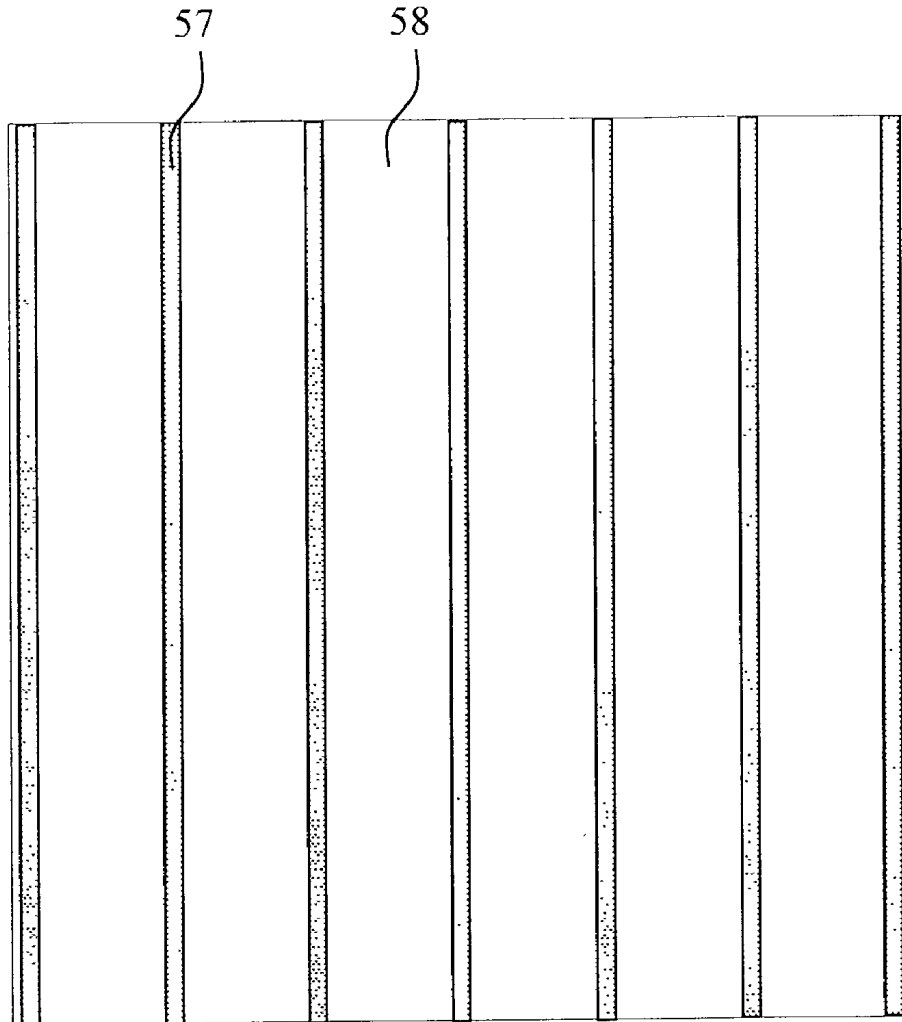

FIG. 13A

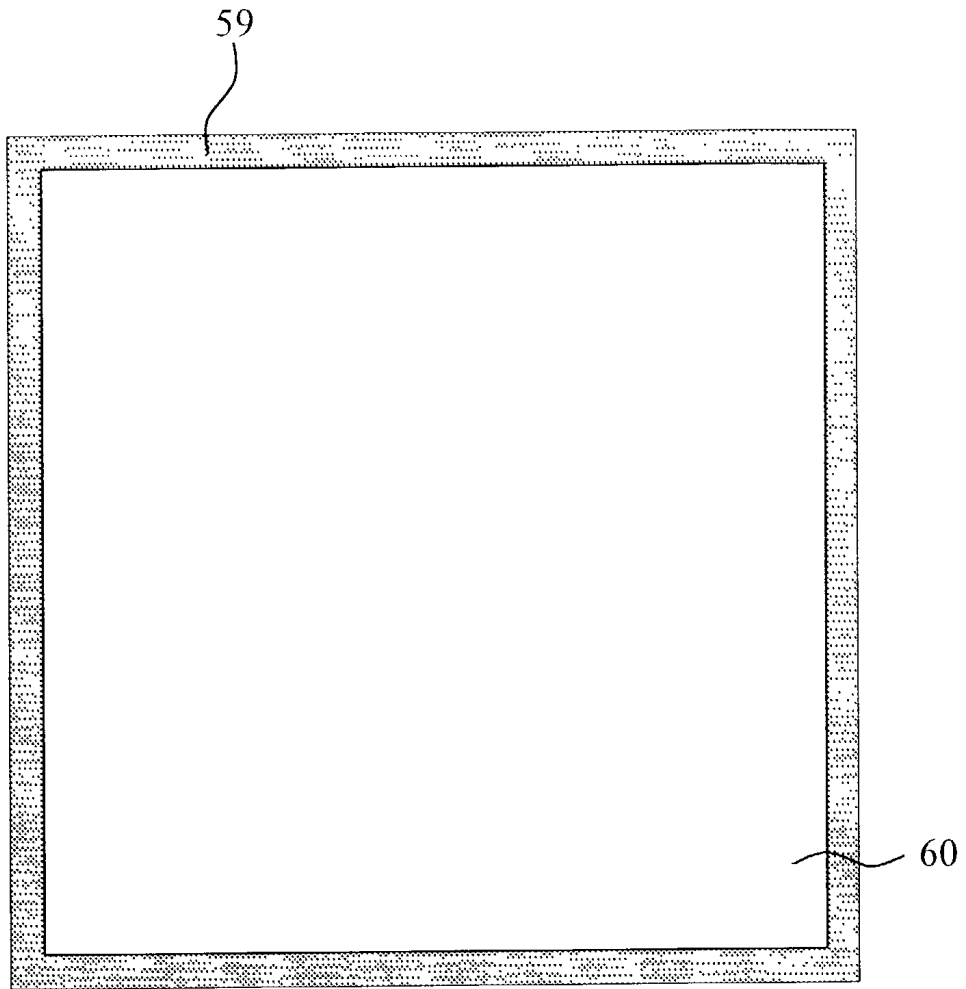
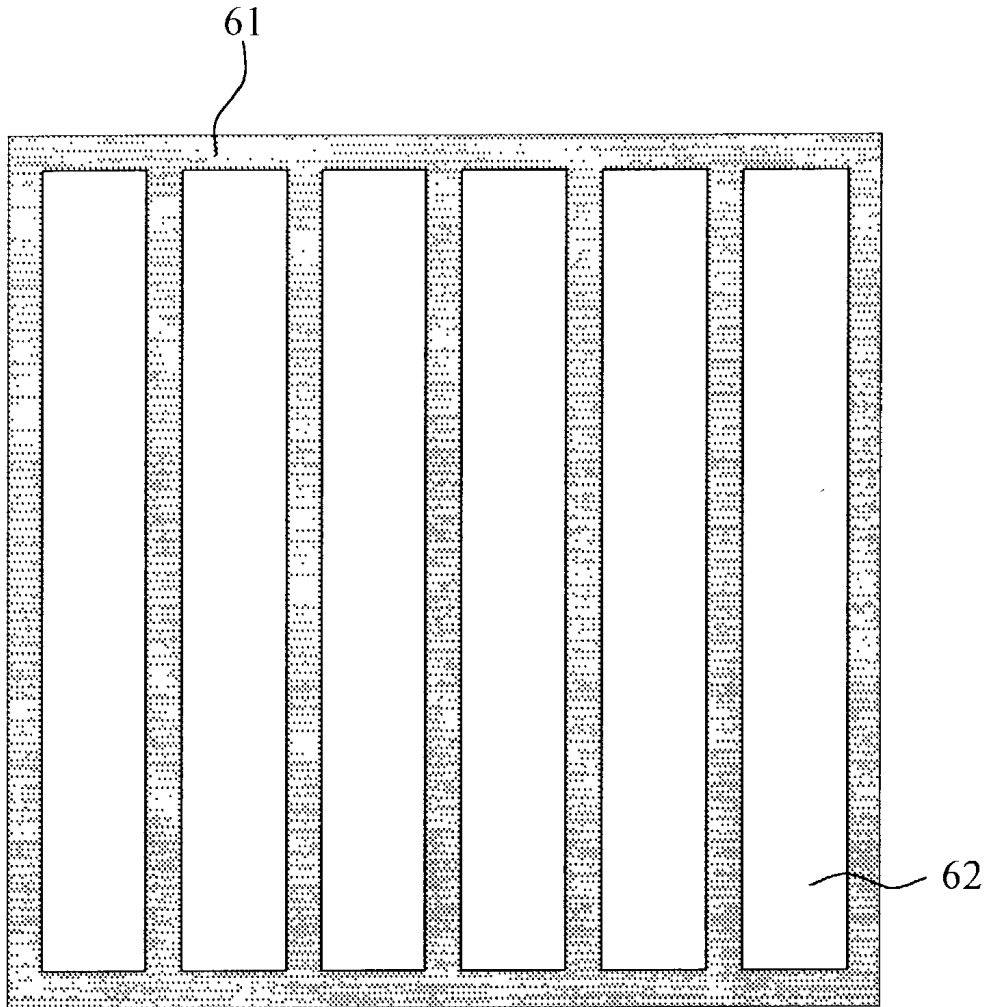

FIG. 13B



ORGANIC ELECTROLUMINESCENCE DISPLAY AND FABRICATING METHOD THEREOF

BACKGROUND OF THE INVENTION 1. Field of the Invention

[0001] The present invention relates to an organic electroluminescence display, and more particularly, to an organic electroluminescence display and a fabricating method thereof enabling to simplify a fabricating process by forming a single insulating layer pattern having functions of an insulating layer and barrier ribs, upgrade an image quality by increasing an opening ratio, and reduce a product cost.

[0002] 2. Background of the Related Art

[0003] Generally, an organic electroluminescence (hereinafter abbreviated EL) display is one of flat panel displays, includes an organic EL layer inserted between anode and cathode layers on a substrate so as to be thin, and can be formed like a matrix type. Different from a plasma display panel (PDP) as another emissive display requiring a high driving voltage over 200V, the organic EL display as an emissive display can be driven by a low voltage below 15V so as to be suitable for a portable device. Compared to TFT-LCD as a non-emissive display, the organic EL display has higher brightness and wider viewing angle as well as more excellent characteristics such as a response speed below about 1 μ sec and the like. Specifically, the organic EL display has the response speed more excellent than those of other flat panel displays, thereby being very suitable for an IMT-200 mobile phone to which a function of moving pictures is essential.

[0004] Yet, since an organic EL layer and a cathode layer of such an organic EL display are vulnerable to oxygen and moisture, surroundings of a fabrication process should be made airtight in order to secure a reliance of the organic EL display. Hence, the fabrication process is unable in general to use photolithography for pixellation or patterning.

[0005] Therefore, pixellation of organic and cathode layers of the organic EL display uses direct pixellation using a shadow mask instead of photolithography including masking/etching processes exposed to oxygen and moisture. Yet, such a method is inadaptable to use if a pitch between pixels, i.e. an interval between lines of the organic and cathode layers, is reduced so as to realize high resolution.

[0006] There is another method of patterning the organic EL display, which is carried out in a manner that a cathode layer is patterned using a separator after an insulating layer and a separator have been formed with an electrically insulating material on an anode layer and a substrate.

[0007] In this case, the insulating layer is formed on an entire area of the anode layer except a dot-like opening area. The insulating layer defines pixels, inhibits leakage current from edges of the cathode, and prevents the organic layer from being short-circuited at a boundary between the cathode and anode layers since the stacked organic layer becomes thinner near the separator due to a shadow effect by the separator in a direction vertical to the anode layer formed for patterning of the cathode layer.

[0008] The separator formed on the insulating layer crosses with the anode layer to be arranged so as to leave an interval from each other as well as has an overhang structure

so as not to make the cathode layer be short-circuited with an adjacent component. Specifically, unlike a general patterning process, a negative profile should be maintained in order to prevent short-circuit between adjacent cathode layer lines. If the separator is missing, there is a chance to be short-circuited with an adjacent pixel.

[0009] In order to fabricate the organic EL display stably, both of the insulating layer and separator are necessary. Yet, each process requires photolithography, thereby becoming complicated as well as increasing a product cost of the organic EL display.

[0010] A method of fabricating an organic EL display according to a related art is explained in detail by referring to the attached drawings as follows.

[0011] FIGS. 1A to 1C illustrate layouts of an organic EL display according to a related art.

[0012] Referring to FIG. 1A, a plurality of first electrodes 2 formed of ITO (indium tin oxide) or the like are arranged like a stripe type on a transparent substrate 1.

[0013] Referring to FIG. 1B, a lattice type insulating layer pattern 3 is stacked on the first electrodes 2 and transparent substrate 1 in an area between the first electrodes 1 and an area crossing with the first electrodes 2 except dot-like openings on the first electrodes 2.

[0014] Referring to FIG. 1C, separators 4 are formed on the insulating layer pattern 3 between the dot-like openings so as to cross with the first electrodes 2. Although not shown in the drawing, an organic EL layer and second electrodes (cathode layer) are stacked on the first electrodes 2 including the insulating layer pattern 3 and separators 4.

[0015] FIGS. 2A to 2C illustrate cross-sectional views of a method of fabricating an organic EL display along cutting lines A-A' in FIGS. 1A to 1C according to a related art.

[0016] Referring to FIG. 2A, an anode layer (not shown in the drawing) formed of ITO (indium tin oxide) or the like is stacked with a predetermined thickness on a transparent substrate 1 by sputtering. A photoresist layer (not shown in the drawing) is coated on the entirely-deposited anode layer. Exposure and development are carried out on the photoresist layer using a mask so as to form a stripe type photoresist pattern (not shown in the drawing). The entirely-deposited anode layer is etched using the photoresist pattern. And, the photoresist pattern is removed so as to form stripe type patterns of first electrodes 2.

[0017] Referring to FIG. 2B, an insulating layer (not shown in the drawing) is stacked for electric insulation on the transparent substrate 1 including the first electrodes 2. The insulating layer can be formed with organic or inorganic material. The organic material uses resin or photoresist including acrylic-, novolac-, or epoxy-based material. And, the inorganic material uses silicon oxide, silicon nitride, silicon oxinitride, or the like. The insulating layer is patterned so as to form a lattice type insulating layer pattern 3 on the first electrodes 2 and transparent substrate 1 except the dot-like openings formed on the first electrodes 2.

[0018] Referring to FIG. 2C, a negative type organic photoresist layer (not shown in the drawing) is stacked on the insulating layer pattern 3 using an electrically insulating material, and then a patterning process is carried out so as to

form separators **4** having a negative profile. In this case, the separators **4** are arranged on the insulating layer pattern **3** between the dot-like openings so as to cross with the first electrodes **2**, and has an overhang structure so as to prevent second electrodes **6** from being short-circuited with adjacent components. And, an organic EL layer **5** and second electrodes **6** are stacked in order using a shadow mask(not shown in the drawing).

[0019] In order to protect the organic EL layer and second electrodes(cathode layer) and the like vulnerable to moisture and oxygen, an encapsulation layer formed of metal, glass, or the like or a passivation layer formed of inorganic or organic material is formed on an entire surface including the second electrodes **6** so as to make the organic EL display airtight from outside.

[0020] FIGS. 3A to 3C illustrate cross-sectional views of a method of fabricating an organic EL display along cutting lines B-B' in FIGS. 1A to 1C according to a related art.

[0021] FIGS. 4A to 4C illustrate layouts of an organic EL display according to another related art.

[0022] Referring to FIG. 4A, a plurality of first electrodes **2** formed of ITO(indium tin oxide) or the like are arranged like a stripe type on a transparent substrate **1**.

[0023] Referring to FIG. 4B, a stripe type insulating layer pattern **3** is stacked on the transparent substrate **1** and an area crossing with the first electrodes **2** on the first electrodes **2**.

[0024] Referring to FIG. 4C, a photoresist layer **7** is formed on the transparent substrate **1** including the first electrodes **2** and insulating layer pattern **3**. The photoresist layer **7** fails to cover openings **8** exposing the first electrodes **2** and middle portions of the insulating layer pattern **3** in the same direction of the insulating layer pattern **3**. Trenches **9** are then formed by etching the exposed middle portions of the insulating layer pattern **3** with a predetermined thickness. Thus, the photoresist layer **7** exposes the openings on the first electrodes **2** so as to construct a lattice shape overall. An organic EL layer formed on the first electrodes **2** including the openings **8** and second electrodes(cathode layer) are not shown in the drawing.

[0025] FIGS. 5A to 5C illustrate cross-sectional views of a method of fabricating an organic EL display along cutting lines A-A' in FIGS. 4A to 4C according to another related art.

[0026] Referring to FIG. 5A, an anode layer(not shown in the drawing) formed of ITO(indium tin oxide) or the like is stacked with a predetermined thickness on a transparent substrate **1** by sputtering. A photoresist layer(not shown in the drawing) is coated on the entirely-deposited anode layer. Exposure and development are carried out on the photoresist layer using a mask so as to form a stripe type photoresist pattern(not shown in the drawing). The anode layer is etched using the photoresist pattern. And, the photoresist pattern is removed so as to form stripe type patterns of first electrodes **2**.

[0027] An insulating layer(not shown in the drawing) is stacked for electric insulation on the transparent substrate **1** including the first electrodes **2**. The insulating layer is formed with silicon oxide, silicon nitride, silicon oxinitride, or the like by vacuum deposition such as sputtering, chemical vapor deposition, or the like. The insulating layer is

patterned by photolithography so as to form insulating layer patterns **3**, which are arranged to leave an interval from each other so as to cross with a plurality of the first electrodes **2**.

[0028] Referring to FIG. 5B, a positive type photoresist layer **7** is stacked on the insulating layer patterns **3** using an electrically insulating material, and then exposure and development are carried out on the photoresist layer **7** so as to form openings exposing the first electrodes **2** as well as expose middle portions of the insulating patterns **3** in parallel with the insulating patterns **3**, respectively.

[0029] Referring to FIG. 5C, trenches **9** are formed by etching the middle portions of the insulating patterns **3** using the patterned photoresist layer **7**, respectively. A cross-section of each of the trenches **9** looks rectangular. Yet, the cross-section is a trapezoid or a half-circle. And, the structure of the trench **9** prevents short-circuit between the adjacent second electrodes(cathode layer).

[0030] And, an organic EL layer(not shown in the drawing) and second electrodes(not shown in the drawing) are stacked in order.

[0031] In order to protect the organic EL layer and second electrodes(cathode layer) and the like vulnerable to moisture and oxygen, an encapsulation layer formed of metal, glass, or the like or a passivation layer formed of inorganic or organic material is formed on an entire surface including the second electrodes so as to be isolated from outside.

[0032] Unfortunately, the method of fabricating the organic EL display according to the related art has the following problems or disadvantages.

[0033] The patterns of the insulating layer define pixels, inhibit leakage current from edges of the cathode, and prevent the organic layer from being short-circuited at a boundary between the cathode and anode layers since the stacked organic layer becomes thinner near the separator due to a shadow effect by the separator in a direction vertical to the anode layer formed for patterning of the cathode layer. The separator formed on the insulating layer crosses with the anode layer to be arranged so as to leave an interval from each other as well as has an overhang structure so as not to make the cathode layer be short-circuited with an adjacent component. Specifically, unlike a general patterning process, a negative profile should be maintained in order to prevent short-circuit between adjacent cathode layer lines. In order to fabricate the organic EL display stably, both of the insulating layer and separator are necessary. Yet, each process requires photolithography, thereby being complicated as well as increasing a product cost of the organic EL display.

SUMMARY OF THE INVENTION

[0034] Accordingly, the present invention is directed to an organic EL display and fabricating method thereof that substantially obviate one or more problems due to limitations and disadvantages of the related art.

[0035] An object of the present invention is to provide an organic EL display and fabricating method thereof enabling to reduce a process time by simplifying a fabricating process in a manner that a pattern of a single insulating layer is formed so as to have both functions of insulator and separator, increase an opening ratio, and reduce a product cost.

[0036] Additional advantages, objects, and features of the invention will be set forth in part in the description which follows and in part will become apparent to those having ordinary skill in the art upon examination of the following or may be learned from practice of the invention. The objectives and other advantages of the invention may be realized and attained by the structure particularly pointed out in the written description and claims hereof as well as the appended drawings.

[0037] To achieve these objects and other advantages and in accordance with the purpose of the invention, as embodied and broadly described herein, an organic electroluminescence display according to the present invention includes a plurality of stripe type first electrodes on a transparent substrate, an insulating layer pattern stacked on the transparent substrate and the first electrodes so as to cross with the first electrodes, a half tone pattern of insulator stacked on the transparent substrate between the insulating layer pattern and between the first electrodes, a plurality of organic light-emitting layers on a plurality of the first electrodes, respectively, and a plurality of second electrodes on a plurality of the second electrodes.

[0038] In another aspect of the present invention, a method of fabricating an organic electroluminescence display includes the steps of forming a plurality of stripe type first electrodes on a transparent substrate, stacking an insulating layer pattern on a first area crossing with the first electrodes and a second area in parallel with the first electrodes wherein a half tone pattern is formed on the second area, forming a plurality of organic light-emitting layers on a plurality of the first electrodes, respectively, and forming a plurality of second electrodes on a plurality of the second electrodes.

[0039] It is to be understood that both the foregoing general description and the following detailed description of the present invention are exemplary and explanatory and are intended to provide further explanation of the invention as claimed.

BRIEF DESCRIPTION OF THE DRAWINGS

[0040] The accompanying drawings, which are included to provide a further understanding of the invention and are incorporated in and constitute a part of this application, illustrate embodiment(s) of the invention and together with the description serve to explain the principle of the invention. In the drawings:

[0041] FIGS. 1A to 1C illustrate layouts of an organic EL display according to a related art;

[0042] FIGS. 2A to 2C illustrate cross-sectional views of a method of fabricating an organic EL display along cutting lines A-A' in FIGS. 1A to 1C according to a related art;

[0043] FIGS. 3A to 3C illustrate cross-sectional views of a method of fabricating an organic EL display along cutting lines B-B' in FIGS. 1A to 1C according to a related art;

[0044] FIGS. 4A to 4C illustrate layouts of an organic EL display according to another related art;

[0045] FIGS. 5A to 5C illustrate cross-sectional views of a method of fabricating an organic EL display along cutting lines A-A' in FIGS. 4A to 4C according to another related art;

[0046] FIGS. 6A to 6C illustrate layouts of an organic EL display according to a first embodiment of the present invention;

[0047] FIGS. 7A to 7C illustrate cross-sectional views of a method of fabricating an organic EL display along cutting lines A-A' in FIGS. 6A to 6C according to a first embodiment of the present invention;

[0048] FIGS. 8A to 8C illustrate cross-sectional views of a method of fabricating an organic EL display along cutting lines B-B' in FIGS. 6A to 6C according to a first embodiment of the present invention;

[0049] FIG. 9A and FIG. 9B illustrate layouts of an organic EL display according to a second embodiment of the present invention;

[0050] FIGS. 10A to 10D illustrate cross-sectional views of a method of fabricating an organic EL display along cutting lines A-A' in FIG. 9A and FIG. 9B according to a second embodiment of the present invention;

[0051] FIGS. 11A to 11D illustrate cross-sectional views of a method of fabricating an organic EL display along cutting lines B-B' in FIG. 9A and FIG. 9B according to a second embodiment of the present invention;

[0052] FIGS. 12A to 12C illustrate layouts of exposure masks used for fabricating organic EL displays according to the first and second embodiments of the present invention; and

[0053] FIG. 13A and FIG. 13B illustrate layouts of shadow masks used for fabricating organic EL displays according to the first and second embodiments of the present invention.

DETAILED DESCRIPTION OF THE PREFERRED EMBODIMENTS

[0054] Reference will now be made in detail to the preferred embodiments of the present invention, examples of which are illustrated in the accompanying drawings.

[0055] FIGS. 6A to 6C illustrate layouts of an organic EL display according to a first embodiment of the present invention.

[0056] Referring to FIG. 6A, a plurality of stripe type first electrodes 22 formed of ITO(indium tin oxide) or the like are arranged on a transparent substrate 21 using an exposure mask shown in FIG. 12A.

[0057] Referring to FIG. 6B, an insulating layer pattern 23 is formed on the first electrodes 22 and transparent substrate 21 using a half-tone mask shown in FIG. 12B so as to lie between a plurality of the first electrodes 22 and cross with a plurality of the first electrodes 22. Thus, openings 25 are formed on the first electrodes 22 so as to expose areas in which pixels are formed, respectively. And, the insulating layer pattern 23 has a lattice shape having the openings 25 in which the pixels are formed respectively.

[0058] And, a portion 24 of the insulating layer pattern 23 running on a direction in parallel with the first electrodes 22 is a half tone pattern 24. The half tone pattern 24 is formed to be lower than the other portion of the insulating layer pattern 23 running in a direction vertical to the first electrodes 22 using the exposure mask of normal tone.

[0059] The reason why the half tone pattern 24 is formed is that leakage current generated from edges of the first electrodes should be inhibited and that a possibility of disconnection generated from a deposited layer of second electrodes becoming thinner at a boundary between ends of a photoresist layer and the first electrodes 22 should be excluded. In this case, the second electrodes are formed in a direction vertical to the first electrodes 22.

[0060] Referring to FIG. 6C, a trench 26 is formed in each middle portion of the insulating pattern 23 stacked in a direction vertical to the first electrodes 22 using a normal tone exposure mask shown in FIG. 12C, and preferably, a half tone exposure mask. In this case, a predetermined portion of a photoresist layer is made to remain after development. If the normal tone exposure mask is used, a portion of the photoresist layer is left by controlling a development time.

[0061] The trench 26 has a function of preventing short-circuit between the second electrodes adjacent to each other. Although not shown in the drawing, an organic EL layer and second electrodes(cathode layer) are stacked on the first electrodes 22 including the openings 25.

[0062] FIGS. 7A to 7C illustrate cross-sectional views of a method of fabricating an organic EL display along cutting lines A-A' in FIGS. 6A to 6C according to a first embodiment of the present invention.

[0063] Since the cutting line A-A' passes the openings 25, a half tone pattern 24 in the openings fails to show up in cross-sectional views in FIG. 7B and FIG. 7C.

[0064] Referring to FIG. 7A, a transparent substrate 21 is prepared. The transparent substrate 21 is preferably formed of one of glass, quartz, plastics, and the like. An anode layer is stacked 1,000~3,000 Å thick on the transparent substrate 21 by depositing ITO(indium tin oxide), IZO(indium zinc oxide), IXO or the like. A sheet resistance of the anode layer is made to be equal to or lower than 10 Ω/cm². The anode layer is stacked on the cleaned transparent substrate 21 by vacuum deposition such as sputtering, CVD(chemical vapor deposition) or the like. Successively, a photoresist layer(not shown in the drawing) is coated on the anode layer, exposure is carried out on the photoresist layer using an anode pattern mask, development is carried out on the exposed photoresist layer so as to form a stripe type photoresist pattern(not shown in the drawing), the anode layer is etched using the photoresist pattern, and the photoresist pattern is removed. Thus, stripe type first electrodes 22 are formed.

[0065] Referring to FIG. 7B, in order to inhibit leakage current from edges of the first electrodes 22, prevent the possibility of short circuit between the first electrodes 22 and second electrodes 28 that will be formed later, and prevent short circuit between the second electrodes 28 and adjacent other patterns, a process of forming an insulating layer is carried out. The present invention uses a photoresist layer-(not shown in the drawing) having an electrically insulating characteristic in order to prevent short circuit between the first electrodes 22 and second electrodes 28 that will be formed later.

[0066] A photoresist layer having a characteristic of image reversal is coated on the transparent substrate 21 having the first electrodes formed thereon. The photoresist layer is formed 1~5 μm thick, and preferably, 3~5 μm thick. AZ

5214E is used for the photoresist layer. This photoresist layer basically has a property of positive photosensitivity. Yet, once the flood exposure is carried out on the photoresist layer heated at a constant temperature, generally over 110° C., the property of positive photosensitivity is changed into that of negative photosensitivity.

[0067] After the photoresist layer has been coated, pre-baking is carried out at 100° C. for about 60 seconds so as to dry the photoresist layer. And, an insulating layer pattern 23 is formed using a half tone exposure mask like that shown in FIG. 12B. In this case, the insulating layer pattern 23 in a direction in parallel with the first electrodes 22, as shown in FIG. 6B, is a half tone pattern 24, and is formed selectively to leave a predetermined interval from each other. The half tone pattern 24 is formed to be lower than other portions of the insulating layer pattern 23. And, the half tone pattern 24 is preferably under 2μm thick. A thickness of the half tone pattern 24 can be controlled by adjusting an opening ratio of a half tone area of the half tone exposure mask shown in FIG. 12B.

[0068] The insulating layer in parallel with the first electrodes 22 is formed with the half tone pattern 24 so as to reduce a thickness of the photoresist layer. This is for excluding the possibility of disconnection at a boundary between edges of the photoresist layer and the first electrodes 28 formed in a direction vertical to that of the first electrodes 22 since a layer thickness of the second electrodes 28 becomes thinner at the boundary on deposition. After exposure, development is carried out so as to realize the insulating layer pattern 23.

[0069] Referring to FIG. 7C, after completion of development, a dry process such as air knife or spin dry is carried out on the transparent substrate 21 at a temperature lower than 100° C. And, a second exposure process is carried out using a mask for forming trenches for separation of second electrodes as shown in FIG. 12C. After completion of the second exposure process, reversal baking is carried out for about 140 seconds at 120° C. Flood exposure is then carried out so as to change the property of the photoresist layer. Since the reversal baking for image reversal after exposure and the flood exposure are carried out, the property of the photoresist layer is changed in a manner that an exposed portion remains but a non-exposed portion is developed.

[0070] In the second exposure process, each middle portion of the insulating pattern 23 stacked in a direction vertical to the first electrodes 22 fails to be exposed with a width narrower than that of the insulating layer pattern 23. Or, the middle portion of the insulating layer pattern 23 is exposed to a small quantity when the half tone mask is used. And, the rest portions of the insulating layer pattern 23 are exposed.

[0071] A trench 26 is formed at each of the middle portions of the insulating layer pattern 23 stacked in a direction vertical to the first electrodes 22 by a development process. When the trench 26 is formed for adjacent pixels isolation, a depth of the trench 26 is preferably greater than a sum of the deposition thickness of the organic EL layer 27 and second electrode 28 that are deposited later. Specifically, the depth of the trench 26 is at least twice greater than the total thickness of the organic EL layer 27 and second electrode 28. In the present invention, the trench is formed about 2 μm deep.

[0072] Moreover, a predetermined amount of the photoresist layer should remain at the bottom of the trench so as to prevent short circuit between the first electrodes through metal of the second electrodes deposited inside the trench. Hence, a pattern of the mask for forming the trench is preferably a half tone type. If the mask is a normal tone, a predetermined portion of the photoresist layer is left by controlling a development time. And, the remaining thickness of the photoresist layer is preferably over 0.5 μm .

[0073] Subsequently, the transparent substrate 21 undergoes a post-baking process so as to be transferred inside a vacuum deposition apparatus for forming an organic EL layer 27. And, an organic EL layer is stacked on the transparent substrate 21 including the insulating layer pattern 23. In this case, the organic EL layer 27 is formed of one of fluorescent low molecular materials such as Alq_3 and anthracene, phosphorescent low molecular materials such as iridium coordination compounds such as $\text{Ir}(\text{ppy})_3$ and their derivatives, and high molecular organic luminescent materials such as PPV[poly(phenylenevinylene)], PT(polythiophene), etc. and their derivatives. The low molecular based material is patterned by thermal evaporation using a shadow mask installed inside a chamber. And, the high molecular based material is patterned by spin coating, transcription, ink jet, or the like so as to be formed at a designed position.

[0074] When the molecular based material is used, injection and transport efficiencies of holes from the anode are increased by forming a hole transport layer in and on a hole injection layer before the formation of the organic EL layer 27 as well as an injection efficiency of electrons from the cathode is improved by forming electron transport and injection layers on the organic EL layer. When a hole injection electrode having a high work function is used, the hole injection layer is an organic film having properties of enabling to have massive holes injected therein as well as let the injected hole move therein. Even if being unable to have the holes injected therein, or if the injection is possible, the hole injection layer is the organic film having a property of being unable to have the holes move therein. Moreover, when an electron injection electrode having a low work function is used, the electron transport layer is an organic film having properties of enabling to have massive electrons injected therein as well as let the injected electrons move therein. Even if being unable to have the electrons injected therein, the electron transport layer is the organic film having a property of being unable to let the electrons move therein.

[0075] When the high molecular based material is used, unlike the case of the low molecular based material, a double structure constituted with buffer and organic EL layers is formed between anode and cathode layers.

[0076] Second electrodes 28 are formed on the transparent substrate 21 including the organic EL layer 27 using a frame mask as a shadow mask having a pattern opening a device area in FIG. 13A. The second electrodes 28 mainly use a metal having an excellent electric conductivity such as Al, Li/Al, MgAg, Ca, or the like, and are stacked by vacuum deposition such as sputtering, electron beam, thermal evaporation, or the like. And, In order to protect the organic EL layer vulnerable to moisture and oxygen, an encapsulation layer formed of metal, glass, or the like or a passivation layer

formed of inorganic or organic material is formed on the transparent substrate 21 including the second electrodes 28 so as to make the organic EL layer airtight from outside.

[0077] FIGS. 8A to 8C illustrate cross-sectional views of a method of fabricating an organic EL display along cutting lines B-B' in FIGS. 6A to 6C according to a first embodiment of the present invention.

[0078] Unlike FIG. 7, since the cutting line fails to traverse the opening 25, cross-sectional views in FIG. 8B and FIG. 8C show that a half tone pattern 24 is formed thinner than other insulating layer pattern 23.

[0079] A method of fabricating an organic EL display according to a second embodiment of the present invention is explained in detail as follows.

[0080] FIG. 9A and FIG. 9B illustrate layouts of an organic EL display according to a second embodiment of the present invention.

[0081] Referring to FIG. 9A, a plurality of stripe type first electrodes 42 formed of ITO(indium tin oxide) or the like are arranged on a transparent substrate 41 using an exposure mask shown in FIG. 12A.

[0082] Referring to FIG. 9B, an insulating layer pattern 43 is formed on the first electrodes 42 and transparent substrate 41 using a half-tone mask shown in FIG. 12B so as to lie between a plurality of the first electrodes 42 and cross with a plurality of the first electrodes 42. Thus, openings 45 are formed on the first electrodes 42 so as to expose areas in which pixels are formed, respectively. And, the insulating layer pattern 43 has a lattice shape having the openings 45 in which the pixels are formed respectively.

[0083] And, a portion 44 of the insulating layer pattern 43 running on a direction in parallel with the first electrodes 42 is a half tone pattern 44. The half tone pattern 44 is formed to be lower than the other portion of the insulating layer pattern 43. The reason why the half tone pattern 44 is formed is that a possibility of disconnection generated from a deposited layer of second electrodes(not shown in the drawing) becoming thinner at a boundary between ends of a photoresist layer and the first electrodes 42 should be excluded. In this case, the second electrodes are formed in a direction vertical to the first electrodes 42.

[0084] FIGS. 10A to 10D illustrate cross-sectional views of a method of fabricating an organic EL display along cutting lines A-A' in FIG. 9A and FIG. 9B according to a second embodiment of the present invention.

[0085] Since the cutting line A-A' passes the openings 45, a half tone pattern 44 in areas of the openings 45 fails to show up in cross-sectional views in FIG. 10B and FIG. 10C.

[0086] Referring to FIG. 10A, a transparent substrate 41 is prepared. The transparent substrate 41 is preferably formed of one of glass, quartz, plastics, and the like. An anode layer(not shown in the drawing) is stacked 1,500~2,000 \AA thick on the transparent substrate 41 by depositing ITO(indium tin oxide), IZO(indium zinc oxide), IXO or the like. A sheet resistance of the anode layer is made to be equal to or lower than 10 Ω/cm^2 . The anode layer is stacked on the cleaned transparent substrate 21 by sputtering or the like. Successively, a photoresist layer(not shown in the drawing)

is coated on the anode layer, exposure is carried out on the photoresist layer using a mask, development is carried out on the exposed photoresist layer so as to form a stripe type photoresist pattern(not shown in the drawing), the anode layer is etched using the photoresist pattern, and the photoresist pattern is removed. Thus, stripe type first electrodes 42 are formed.

[0087] Referring to FIG. 10B, in order to inhibit leakage current from edges of the first electrodes 42, prevent the possibility of short circuit between the first electrodes 42 and second electrodes 48 that will be formed later, and prevent short circuit between the second electrodes 48, a process of forming an insulating layer is carried out. The present invention uses a photoresist layer(not shown in the drawing) having an electrically insulating characteristic.

[0088] A photoresist layer is coated on the transparent substrate 41. The photoresist layer is formed 1~5 μm thick, and preferably, 3~5 μm thick. And, an insulating layer pattern 43 is formed using a half tone exposure mask(not shown in the drawing). In this case, the insulating layer pattern 43 in a direction in parallel with the first electrodes 42, as shown in FIG. 9B, is a half tone pattern 44, and is formed selectively. The half tone pattern 44 is formed to be lower than other portions of the insulating layer pattern 43 using a half tone exposure mask by means of controlling an exposure amount. And, the half tone pattern 44 is preferably under 2 μm thick. A thickness of the half tone pattern 44 can be controlled by adjusting an opening ratio of a half tone area by a pattern drawn on the exposure mask.

[0089] The insulating layer in parallel with the first electrodes 42 is formed with the half tone pattern 44 so as to reduce a thickness of the photoresist layer. This is for excluding the possibility of disconnection at a boundary between edges of the photoresist layer and the first electrodes 48 formed in a direction vertical to that of the first electrodes 42 since a layer thickness of the second electrodes(not shown in the drawing) becomes thinner at the boundary on deposition.

[0090] Referring to FIG. 10C, the transparent substrate 41 is transferred inside a vacuum deposition apparatus for forming an organic EL layer 47. The organic EL layer 47 is formed on the first electrodes 42 through the openings 45 using the insulating layer pattern 43 as a support of a first shadow mask 49. Since the insulating layer pattern 43 is used as the support so as to adhere closely to the first shadow mask 49 without causing any damage on the first electrodes 42. Hence, it is able to prevent lateral diffusion of the organic EL layer 47.

[0091] In this case, the organic EL layer 47 is formed of one of fluorescent low molecular materials such as Alq_3 and anthracene, phosphorescent low molecular materials such as iridium coordination compounds such as Ir(ppy)_3 and their derivatives, and high molecular organic luminescent materials such as PPV[poly(phenylenevinylene)], PT(polythiophene), etc. and their derivatives.

[0092] Before the formation of the organic EL layer 47, a hole injection layer and a hole transport layer can be stacked. Moreover, electron transport and injection layers can be formed on the organic EL layer.

[0093] When a hole injection electrode having a high work function is used, the hole injection layer is an organic film

having properties of enabling to have massive holes injected therein as well as let the injected hole move therein. Even if being unable to have the holes injected therein, or if the injection is possible, the hole injection layer is the organic film having a property of being unable to have the holes move therein. Moreover, when an electron injection electrode having a low work function is used, the electron transport layer is an organic film having properties of enabling to have massive electrons injected therein as well as let the injected electrons move therein. Even if being unable to have the electrons injected therein, the electron transport layer is the organic film having a property of being unable to let the electrons move therein.

[0094] Referring to FIG. 10D, second electrodes 48 are formed on the organic EL layer 47 using the insulating layer pattern 43 as a support of a second shadow mask 50 having a stripe type electrode pattern shown in FIG. 14B. The insulating layer pattern 43 used as the support enables to adhere closely to the second shadow mask 50 without causing any damage on the organic EL layer 47, thereby enabling to prevent lateral diffusion of the second electrodes 48.

[0095] The second electrodes 48 mainly use a metal having an excellent electric conductivity such as Al, Li/Al, MgAg, Ca, or the like, and are stacked by vacuum deposition such as sputtering, electron beam, thermal evaporation, or the like. And, in order to protect the organic EL layer 47 vulnerable to moisture and oxygen, an encapsulation layer formed of metal, glass, or the like or a passivation layer formed of inorganic or organic material is formed on the transparent substrate 41 including the second electrodes 48 so as to make the organic EL layer airtight from outside.

[0096] FIGS. 11A to 11D illustrate cross-sectional views of a method of fabricating an organic EL display along cutting lines B-B' in FIG. 9A and FIG. 9B according to a second embodiment of the present invention.

[0097] Like FIG. 10, since the cutting line fails to traverse the opening 45 but passes a half tone pattern, cross-sectional views in FIGS. 11B to 11D show that the half tone pattern 44 is formed thinner than other insulating layer pattern 43.

[0098] FIGS. 12A to 12C illustrate layouts of exposure masks used for fabricating organic EL displays according to the first and second embodiments of the present invention.

[0099] Referring to FIG. 12A, an exposure mask arranges a plurality of the first electrodes 22 or 42 formed of ITO(indium tin oxide) or the like on the transparent substrate 21 or 41. the exposure mask includes a light-transmitting area 51 for forming the first electrodes 22 or 42 and a shield area 52.

[0100] Referring to FIG. 12B, a half tone exposure mask forms the lattice type insulating layer pattern 23 or 43 on an area between a plurality of the first electrodes 22 or 42 and on another area crossing with a plurality of the first electrodes 22 or 42. The half tone exposure mask includes a shield area 53 crossing with the first electrodes 22 or 42, a light-transmitting area 55, and a half tone area in parallel with the first electrodes 22 or 42. The half tone area 54 is constituted with rectangular patterns 56 or slit type patterns 57.

[0101] Referring to FIG. 12C, an exposure mask forms the trenches 26 in middle portions of the insulating layer

pattern stacked in a direction vertical to a plurality of the first electrodes 22, and includes a half tone area 57 and a light-transmitting area 58.

[0102] FIG. 13A and FIG. 13B illustrate layouts of shadow masks used for fabricating organic EL displays according to the first and second embodiments of the present invention.

[0103] Referring to FIG. 13A, a layout of a shadow mask used in the first embodiment of the present invention is shown. The shadow mask includes a shield area 59 and a deposition material transmitting area 60.

[0104] Referring to FIG. 13B, a layout of a shadow mask used in the second embodiment of the present invention is shown. The shadow mask includes a shield area 61 and a deposition material transmitting area 62.

[0105] Accordingly, the organic EL display and fabricating method thereof according to the present invention have the following advantages or effects.

[0106] Using a single photosensitive layer having an insulating property, leakage current at edges of the anode layer is inhibited, short circuit at a boundary between the anode and cathode layers, a function of preventing short circuit between adjacent patterns in the cathode layer is satisfied. Therefore, the present invention simplifies a fabrication process to reduce a process time as well as reduce a product cost.

[0107] Specifically, in the insulating layer pattern formed on the transparent substrate, a portion of the insulating pattern formed on an area in parallel with the anode layer is formed thinner than other portion of the insulating layer pattern. Therefore, the present invention excludes the possibility of disconnection of the cathode layer.

[0108] Moreover, an image-reversible organic material from the positive type to the negative type is used for the insulating layer so as to form the trenches in a direction vertical to the anode layer. Therefore, the present invention enables to form a single photosensitive layer performing both functions of the separator and insulating layer.

[0109] Besides, compared to the organic EL display forming the separator and insulating layer separately according to the related art, the present invention forms the single insulating layer having both functions of the insulating layer and separator, thereby enabling to increase the opening ratio.

[0110] And, since the insulating layer pattern is used as the support of the shadow mask on forming the cathode layer, the shadow mask enables to adhere closely thereto without causing any damage on the organic EL layer as well as prevent lateral diffusion of the cathode layer.

[0111] The forgoing embodiments are merely exemplary and are not to be construed as limiting the present invention. The present teachings can be readily applied to other types of apparatuses. The description of the present invention is intended to be illustrative, and not to limit the scope of the claims. Many alternatives, modifications, and variations will be apparent to those skilled in the art.

What is claimed is:

1. An organic electroluminescence display comprising:
 - a plurality of stripe type first electrodes on a transparent substrate;
 - an insulating layer pattern stacked on the transparent substrate and the first electrodes so as to cross with the first electrodes;
 - a half tone pattern of insulator stacked on the transparent substrate between the insulating layer pattern and between the first electrodes;
 - a plurality of organic light-emitting layers on a plurality of the first electrodes, respectively; and
 - a plurality of second electrodes on a plurality of the second electrodes.
2. The organic electroluminescence display of claim 1, further comprising a plurality of trenches on middle portions of the insulating layer pattern vertical to the first electrodes so as to run in a direction vertical to the first electrodes, respectively.
3. The organic electroluminescence display of claim 2, wherein a lateral side of each of the trenches has an overhang or negative profile structure.
4. The organic electroluminescence display of claim 1, wherein the insulating layer pattern is formed of a photosensitive material having an electrically insulating property.
5. The organic electroluminescence display of claim 1, wherein the half tone pattern in parallel with the first electrodes is thinner than the insulating layer pattern crossing with the first electrodes.
6. The organic electroluminescence display of claim 5, wherein the insulating layer pattern crossing with the first electrodes is 3~5 μm thick and the half tone pattern in parallel with the first electrodes has a thickness equal to or lower than about 2 μm .
7. The organic electroluminescence display of claim 2, wherein a depth of each of the trenches is twice greater than a sum of thickness of the organic light-emitting layer and second electrode and wherein the insulating layer remains at least 0.5 μm thick on a bottom of the trenches.
8. The organic electroluminescence display of claim 2, wherein a depth of each of the trenches is about 2 μm .
9. An organic electroluminescence display comprising:
 - a plurality of stripe type first electrodes on a transparent substrate;
 - a first insulating layer pattern stacked on the transparent substrate and the first electrodes so as to cross with the first electrodes;
 - a second insulating layer pattern stacked on the transparent substrate and the first electrodes so as to be thinner than the first insulating layer pattern and in parallel with the first electrodes;
 - a plurality of organic light-emitting layers on a plurality of the first electrodes, respectively; and
 - a plurality of second electrodes on a plurality of the second electrodes.
10. An organic electroluminescence display comprising:
 - a plurality of stripe type first electrodes on a transparent substrate;

- a lattice type insulating layer pattern stacked on the transparent substrate and the first electrodes so as to cross with the first electrodes and lie between the first electrodes;
- a plurality of trenches on middle portions of the insulating layer pattern vertical to the first electrodes so as to cross with the first electrodes;
- a plurality of organic light-emitting layers on a plurality of the first electrodes, respectively; and
- a plurality of second electrodes on a plurality of the second electrodes.
- 11.** A method of fabricating an organic electroluminescence display, comprising the steps of:
- forming a plurality of stripe type first electrodes on a transparent substrate;
- stacking an insulating layer pattern on a first area crossing with the first electrodes and a second area in parallel with the first electrodes wherein a half tone pattern is formed on the second area;
- forming a plurality of organic light-emitting layers on a plurality of the first electrodes, respectively; and
- forming a plurality of second electrodes on a plurality of the second electrodes.
- 12.** The method of claim 11, wherein a half tone area of a mask used for forming the half tone pattern has a shape selected from a group consisting of slit, lattice and chevron.
- 13.** The method of claim 11, wherein a half tone area of a mask used for forming the half tone pattern is formed of a semi-transmitting material having a low transmittance.
- 14.** The method of claim 11, further comprising a step of forming a plurality of trenches on middle portions of the insulating layer pattern vertical to the first electrodes so as to cross with the first electrodes.
- 15.** The method of claim 14, wherein a lateral side of each of the trenches has an overhang structure or a negative profile.
- 16.** The method of claim 14, wherein a pattern of a mask for forming the trenches has a normal or half tone type.
- 17.** The method of claim 11, further comprising the steps of:
- forming a plurality of the organic light-emitting layers on a plurality of the first electrodes using the insulating layer pattern as a support of a first shadow mask; and
- forming a plurality of the second electrodes on a plurality of the organic light-emitting layers using the insulating layer pattern as a support of a second shadow mask.
- 18.** The method of claim 17, wherein a device area of each of the first and second shadow masks has an open structure.
- 19.** The method of claim 17, wherein each of the first and second shadow masks has a plurality of stripe type patterns.
- 20.** The method of claim 19, wherein a plurality of the stripe type patterns of the first and second shadow masks correspond to the insulating layer pattern crossing with a plurality of the first electrodes.
- 21.** The method of claim 11, the step of forming the insulating layer pattern, comprising the steps of:
- coating a photoresist layer on the transparent substrate including the first electrodes wherein the photoresist layer has a property of electrical isolation;
- carrying out exposure and development on the photoresist layer using a first mask so as to form a photoresist pattern on the first and second areas; and
- forming trenches on middle portions of the photoresist pattern on the first area so as to cross with the first electrodes by carrying out exposure on the photoresist pattern using a second mask so as to perform an image reversal of the photoresist pattern and developing the image-reversed photoresist pattern.
- 22.** The method of claim 21, wherein flood exposure is carried out on the photoresist layer having been heated at a temperature over 110° C. so that a property of the photoresist layer is changed into a negative type from a positive type.
- 23.** The method of claim 21, further comprising a step of carrying out pre-baking at 100° C. for about 60 seconds after the photoresist layer has been coated.
- 24.** The method of claim 21, wherein a reversal baking process is carried out for about 140 seconds at 120° C. after the exposure of the photoresist pattern so that the flood exposure is carried out for the image reversal.
- 25.** A method of fabricating an organic electroluminescence display, comprising the steps of:
- forming a plurality of stripe type first electrodes on a transparent substrate;
- forming an insulating layer pattern on the transparent substrate including the first electrodes wherein the insulating layer pattern is stacked on a first area crossing with the first electrodes and a second area in parallel with the first electrodes and wherein the insulating layer pattern on the second area is thinner than that on the first area;
- forming a plurality of organic light-emitting layers on a plurality of the first electrodes, respectively; and
- forming a plurality of second electrodes on a plurality of the second electrodes.
- 26.** The method of claim 25, wherein an upper portion of the insulating layer pattern on the second area is developed to be removed by controlling an exposure amount by a half tone pattern in an exposure mask and wherein a lower portion of the insulating layer pattern remains so as to have a low thickness selectively.
- 27.** The method of claim 25, further comprising the steps of:
- forming a plurality of the organic light-emitting layers on a plurality of the first electrodes using the insulating layer pattern on the first area as a support of a first shadow mask; and
- forming a plurality of the second electrodes on a plurality of the organic light-emitting layers using the insulating layer pattern on the second area as a support of a second shadow mask.
- 28.** A method of fabricating an organic electroluminescence display, comprising the steps of:
- forming a plurality of stripe type first electrodes on a transparent substrate;
- stacking an insulating layer pattern on a first area crossing with the first electrodes and a second area in parallel with the first electrodes wherein a half tone pattern is formed on the second area;

forming a plurality of organic light-emitting layers on a plurality of the first electrodes using the insulating layer pattern on the first area as a support of a first shadow mask; and

forming a plurality of second electrodes on a plurality of the organic light-emitting layers using the insulating layer pattern on the second area as a support of a second shadow mask.

29. The method of claim 28, further comprising a step of forming a plurality of trenches on middle portions of the insulating layer pattern vertical to the first electrodes so as to cross with the first electrodes.

30. The method of claim 29, wherein a lateral side of each of the trenches has a negative profile and the insulating layer pattern is formed of a photosensitive material having a property of an image reversal.

31. The method of claim 29, wherein a pattern of a mask for forming the trenches has a normal or half tone type.

32. An organic electroluminescence display comprising: forming a plurality of stripe type first electrodes on a transparent substrate;

forming a lattice type insulating layer pattern stacked on the transparent substrate and the first electrodes so as to cross with the first electrodes and lie between the first electrodes;

forming a plurality of trenches on middle portions of the insulating layer pattern vertical to the first electrodes so as to cross with the first electrodes;

forming a plurality of organic light-emitting layers on a plurality of the first electrodes, respectively; and

forming a plurality of second electrodes on a plurality of the second electrodes.

33. The method of claim 32, wherein the insulating layer pattern is formed of a photosensitive material having a property of an image reversal.

* * * * *

专利名称(译)	有机电致发光显示器及其制造方法		
公开(公告)号	US20030052596A1	公开(公告)日	2003-03-20
申请号	US10/243829	申请日	2002-09-16
[标]申请(专利权)人(译)	大宇电子服务股份有限公司		
申请(专利权)人(译)	CLD , INC.		
当前申请(专利权)人(译)	大宇电子SERVICE CO. , LTD.		
[标]发明人	YI SEUNG JUN CHOI KYUNG HEE CHOI DO HYUN CHOI YOUNG CHAN		
发明人	YI, SEUNG-JUN CHOI, KYUNG-HEE CHOI, DO-HYUN CHOI, YOUNG-CHAN		
IPC分类号	H05B33/22 H01L27/32 H01L51/50 H05B33/10 H05B33/12 H05B33/00		
CPC分类号	H01L27/3283		
优先权	1020020045940 2002-08-02 KR 1020010057046 2001-09-15 KR		
其他公开文献	US6948993		
外部链接	Espacenet USPTO		

摘要(译)

本发明公开了一种有机EL显示器及其制造方法，其能够通过以形成单个绝缘层的图案的方式简化制造工艺来减少工艺时间，从而具有绝缘体和隔膜的功能，增加开口率，并降低产品成本。本发明包括在透明基板上的多个条形第一电极，在透明基板和第一电极上堆叠以与第一电极交叉的绝缘层图案，在透明基板上堆叠的绝缘体的半色调图案绝缘层图案和第一电极之间，多个第一电极上的多个有机发光层和多个第二电极上的多个第二电极。

